



## Go Get the Rigging Safety Class Done Now!

by Kent H Jorgensen

If you are a Grip than you know that there has been another class added to the Safety Pass classes required by Grips. The two day "R" Rigging Safety Class is being offered ten times a month.

The classes have been offered since December, and about a third of the people who need the class have completed it up to this time. The deadline for the other two thirds of the membership is November 30, 2008.

It is important to complete the class before the deadline. Many employers will not hire people who have not completed their classes. When the Safety Pass program first started and the deadline hit, there were many members who lost days of work until they went and finished their classes. Don't put yourself into the position of having to scramble to get the class and miss out on working.

There are plenty of classes available between now and November for members to complete the classes. This will not always be the case. As more people put off the inevitable the number of seats available will be decreasing. Come October, when you realize that you need to get the class done, the classes may be full. You may have to take off work to get it done.

**GO TAKE THE RIGGING SAFETY CLASS NOW!** Sign up to take the class. It is offered every week Monday/Tuesday and Wednesday/Thursday.

Also, it is offered twice a month on Saturday/Sunday. The Saturday/Sunday class even starts at 9:30 a.m. so you can get a little more sleep after getting off work at 3:00 a.m.

The instructors realize how people in this industry get there jobs, so show up with a cup of coffee, put your phone on vibrate, and enjoy the class. Many people have commented that this is the least objectionable class they have taken. If the phone goes off, quietly get up, go into the hall, and get the job.

The Local encourages you to go and get this done. The article is starting to sound like a nagging A.D., "When are we going to be ready?" The reason for the nagging is experience has shown that a good number of Grips go and get these classes done right away. Then there is a lull. Sisters and Brothers know they will have plenty of time to get the class done. They'll get to it soon. As the deadline approaches members will be hurrying to get into a class. Classes will be full, and some people will lose work because they waited.

Don't be one of the people who waits. Call or go online and sign up (818-502-9932: [www.csatf.org](http://www.csatf.org)). Take the classes now while the class size is low. Avoid losing work because you have to take the rigging class.

The nagging won't stop until you get it done.

*"The nagging won't stop until you get it done."*

# Calendar

April 6, 10:00 am: General Membership Meeting

April 6, 10:00 am: Divers Association Meeting

April 20, 9:00 am: Executive Board Meeting

May 4, 10:00 am: General Membership Meeting

May 18, 9:00 am: Executive Board Meeting

May 26: Memorial Day Holiday: Offices Closed

## 3rd Quarter Dues are Due June 30

Call the accounting office to determine how much you owe

## Retirement Planning Seminar

Motion Picture Industry Pension & Health Plans

Sunday, April 27, 2008

For more details and to register, Call 818-769-0007 ext 627

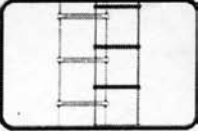
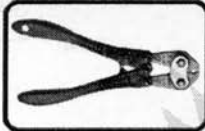

**VER SALES, INC.**  
2509 North Naomi St.  
Burbank, CA. 91504  
(818) 567-3000 fax: (818) 567-3018  
"Over 30 years in the entertainment industry"



Aircraft Cable  
Beam Clamps  
Block & Falls  
Bungee Cord  
Cable Assemblies  
Camera Tape  
Carabiners  
Chain  
Chain Bags  
Chain Motors  
Chesebros  
Coated Cable  
Crosby Clips  
Daisy Chains

Doughty Clamps  
Electrical Tape  
Eyebolts  
Felco Cutters  
First Aid Supplies  
Flashlights  
Gaffers Tape  
Horizontal Lifelines  
Knives  
Manila Rope  
Mtn. Climbing Rope  
Multiline II  
Nicopress  
Pipe Clamps

Pony Clamps  
Pro Master  
Rope  
Sash Cord  
Safety Cables  
Shackles  
Snaps  
Spansets  
Stage Set  
Steel Slings  
Trick Line  
Turnbuckles  
Velcro  
Web Slings

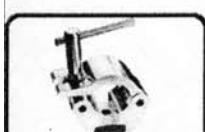

**Rigging • Fall Protection • Hardware • Safety • Rescue Equipment**

See us on the web at [www.versales.com](http://www.versales.com) and [www.versafety.com](http://www.versafety.com)



# A Thank You to Membership for Help to Retirees

“Grip your tools and run,” is the description my husband gives when asked, “What is a Grip?”

He enjoyed being a Grip, working the gang, going high, moving walls, and locations. Those long hours and last minute pack your bags for 30 years; he never complained. I still get a smile from him when he tells me about those old Grip experiences and all

the wonderful people he worked with. By the way, those tools have been hanging on a garage wall for 17 years. Thank you Local 80 for all you do for us retirees!

God Bless You,  
Mrs. Ted Matecki

## Rope and Knot Class

April 6, 1:00 pm to 5:00 pm  
(after the meeting)

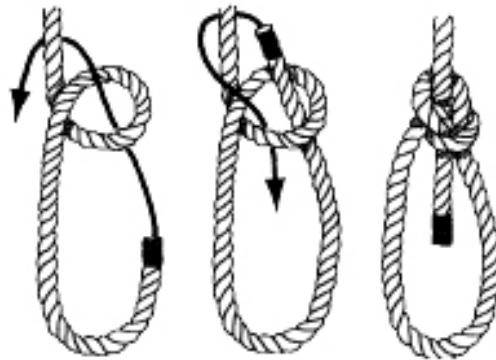

J.L.Fisher

Motion Picture &  
Television Equipment

## Model 23 Sectional JIB

6 to 21 feet... In 10 minutes

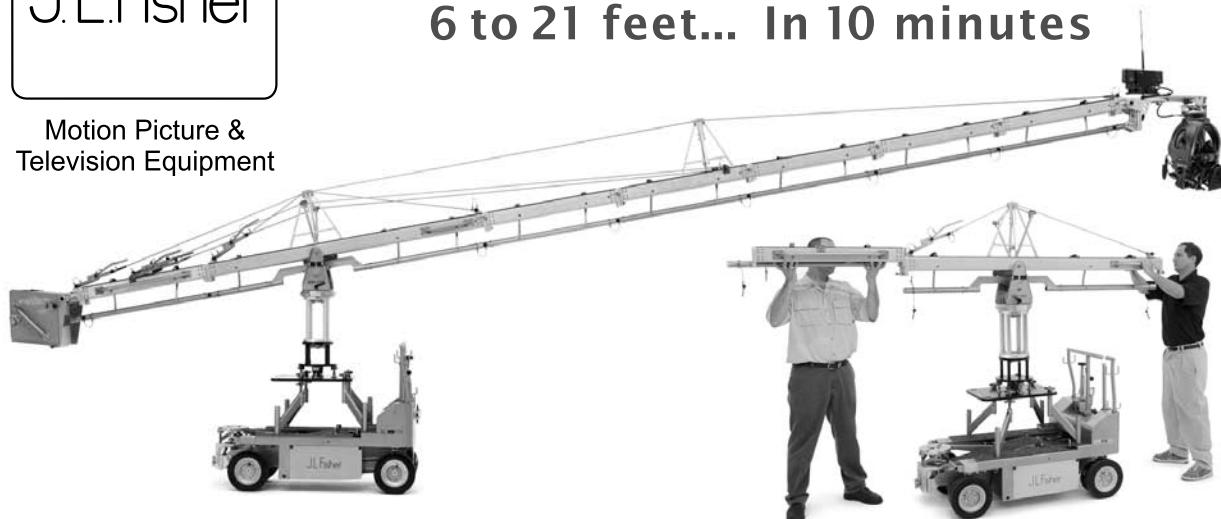

3 foot increments from 6' (1.83m) to 21' (6.4m)

Max payload 131 lbs. (58 kg) @ 21'

***"J.L. Fisher products are proudly made in the U.S.A."***

J.L. Fisher, Inc. 1000 Isabel Street, Burbank, CA 91506 U.S.A.

J.L. Fisher, GmbH Emil-Hoffmann-Str. 55-59 50996 Köln, Germany

Tel: (818) 846-8366 Fax: (818) 846-8699

Tel: +49 2236 3922 0 Fax: +49 2236 3922 12

Web: [www.jlfisher.com](http://www.jlfisher.com) e-mail: [info@jlfisher.com](mailto:info@jlfisher.com)

Web: [www.jlfisher.de](http://www.jlfisher.de) e-mail: [info@jlfisher.de](mailto:info@jlfisher.de)

# CHAPMAN/LEONARD

STUDIO EQUIPMENT, INC. 

**CRANES ARMS BASES REMOTE SYSTEMS DOLLIES PEDESTALS**

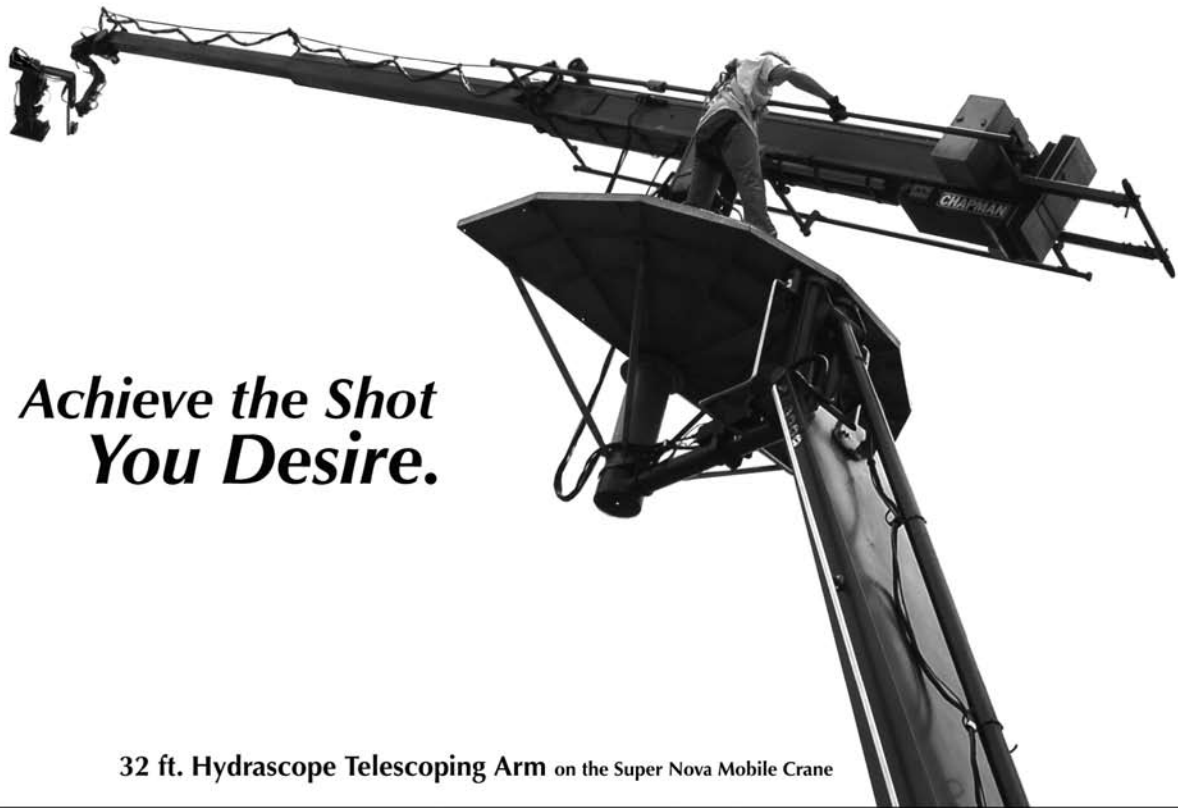

*Achieve the Shot  
You Desire.*

**32 ft. Hydrascope Telescoping Arm on the Super Nova Mobile Crane**



**SUPER NOVA on *Martian Child***



**HUSTLER IV**



**LENNY ARM II PLUS on *Eight Below***

LA (888) 883-6559 TX (888) 758.4826 FL (888) 337-8243 Canada (866) 848-2602 UK (888) 883-6559

© Chapman/Leonard Studio Equipment, Inc.

*Try our Sound Stage in Orlando, Florida*

[www.chapman-leonard.com](http://www.chapman-leonard.com)



**Motion Picture  
& Television  
Fund**  
Taking Care of Our Own<sup>SM</sup>

*The Industry's Trusted Resource*

# ELDER CONNECTION

THE MOTION PICTURE & TELEVISION FUND is excited to announce ELDER CONNECTION, a program of services and referrals for people 65 and older, and those involved with their care.

## Services may include:

- Assessment of care needs, via phone or home visit
- Financial assistance
- Supportive counseling and help for caregivers



Please call for more information 335 N. La Brea Ave.  
or to arrange a referral: Los Angeles, CA 90036  
Phone: 323-634-3866

[www.mptvfund.org](http://www.mptvfund.org)

## Referrals may include:

- Housing alternatives
- Home care agencies
- Transportation
- Home delivered meals
- Legal services
- Support groups
- Medicare and Medi-Cal information

# Divers Association Meeting After the General Membership Meeting Sunday, April 6



## NBC Universal GRIP



- Automated inventory system
- Loading and holding bays
- Expanded inventory
- Steel Deck, Scaffolding
- Large supply of motors and box truss
- Scene Dock
- Rigging crews available on-lot and off-lot
- Ability to accommodate additional needs for key grip rental packages
- Canvas Room
- Pre-loaded 5 and 10 ton grip trucks

818.777.2291 • 800.892.1979 THE FILMMAKERS DESTINATION [WWW.NBCUNI.COM/STUDIO](http://WWW.NBCUNI.COM/STUDIO)



MEDIA WORKS

MEDIA TECHNOLOGY & OPERATIONS

**click**  
*to give!*



**Motion Picture &  
Television Fund  
now accepts  
donations online.  
Taking Care of  
Our Own has never  
been easier!**

**Visit [mptvfund.org](http://mptvfund.org), click 'donate'  
to become part of the safety net  
for the entertainment industry.**

- **Donate** any amount, large or small
- **Make** a one-time gift or set up a recurring gift
- **Designate** where your money goes
- **Check** your own online giving history

**For questions, please call (818) 876-1977.**



### Dues Deferral Application

Name \_\_\_\_\_

Street \_\_\_\_\_

City State Zip \_\_\_\_\_

Cell Phone ( \_\_\_\_\_ ) \_\_\_\_\_ Home Phone ( \_\_\_\_\_ ) \_\_\_\_\_

Last dates of employment Started \_\_\_\_\_ Ended \_\_\_\_\_

Project \_\_\_\_\_

Studio or Production Company name \_\_\_\_\_

Payroll Company \_\_\_\_\_

Are you currently available to work? Yes \_\_\_\_\_ No \_\_\_\_\_

Were you current on dues on December 31, 2007? Yes \_\_\_\_\_ No \_\_\_\_\_

Did you earn more than \$10,000 in the first quarter of 2008? Yes \_\_\_\_\_ No \_\_\_\_\_

**Important:** Failure to notify the callboard of any changes in your employment or availability status within 24 hours will result in all deferred amounts becoming due and payable as of their original due dates.

Deferred dues are still owed to Local 80, and must be repaid in full or in \$100-minimum increments beginning October 1, 2008.

Signature \_\_\_\_\_ Date \_\_\_\_\_

## IATSE Local 80 Phone Menu Bypass Information

The Local utilizes an automated answering system to try and serve the membership. When you call Local 80 you will be greeted by a recorded message and menu, but you don't have to wait for either to play: as soon as the greeting begins you can press the number for the department you want.

- Press 1 for: Accounting (Dues questions or payments)
- Press 2 for: Business Agents (Contract questions or issues)
- Press 3 for: Callboard (Availability and work history)
- Press 4 for: Safety questions or issues, or The Eighty News
- Press 5 for: Permit information
- Press 6 for: Member Services
- Press 7 for: Local 80's address

## From the Desk of the Secretary-Treasurer

Tax day (or, more accurately, tax-filing deadline day) is just around the corner, and this year there is a twist: the great majority of filers are supposed to get a rebate check. The size of your potential rebate varies from several hundred dollars down to nothing according to your income, but is guaranteed to be zero if you don't file.

If you haven't filed already, pull yourself together and get on with it. That rebate is money that you had to fork over in the first place, or, at the very least, that was withheld from your earnings and forked over to the IRS by your employer: don't give them an excuse to hang on to it.

Two of the most common types of calls that the Callboard receives are requests for phone numbers and requests for directions.

Members want the numbers for other members, for the health clinics, for the production office of the last show they worked on or the one they'd like to work on next, for payroll companies, for other Locals, or, it sometimes seems, just about any other number that they don't have programmed into their phones. Production offices or studio departments call to get the numbers for members they would like to hire, or to rent equipment from, or whose call times they want to change or cancel.

Payroll companies call to get current numbers for members whose checks have been returned in the mail due to bad addresses, or whose timecards or start paperwork is illegible, incomplete or missing.

Members call to get directions to the studio, to the location, or to the Safety Pass class that they are supposed to be reporting to but can't find; non-members call to get directions to the Local.

The list is not quite endless, but on a busy day it can certainly seem so to the Call Steward on duty.

There is a common thread that runs through all of these calls: each caller is calling specifically to request information that clearly is of some importance to them and, for the great majority of callers, the information they are asking for is something that they would reasonably expect to need to write down in order to ensure that they are able to retain it accurately.

The common thread tends to fray rather badly at this point, however, as the callers separate into two very different groups: those who are prepared to receive the information that they are requesting, and those who are not.

Members who are Keys or Seconds, along with

people who work in studio departments or production offices almost invariably have pen or pencil in hand and paper in front of them. Among the other callers, primarily composed of would-be Permits and members who seldom, if ever, earn more than the basic rate for their Craft, or ever work steadily for more than a brief period, the probability of such preparedness is considerably lower.

It should come as no surprise to anyone that, while they might be patient during slow spells, the Call Stewards are not inclined to favorable views of callers who waste time during the busy intervals that develop at the Callboard on even the slowest days. (Even during the Writers' strike, when anyone not familiar with their job might be forgiven for thinking that being a Call Steward is easy, there were many occasions when calls came in faster than one person could answer them.)

This isn't about the Call Stewards, however, but about the poor impression that an unprepared caller leaves with the person that they have called.

Much of the earning ability of a below-the-line worker in today's motion picture industry revolves around their job hunting skills, and the great majority of job hunting is done by phone. To fail to be prepared for even so foreseeable task as writing down what a potential employer has to say about when and where they want you to report, or to whom, or who they want you to call next, or, in fact, any information at all is so absurdly unprofessional that it may very easily make them decide that you are not the person that they want to hire or to recommend to others after all.

Disrupting a call to key a phone number into the same phone that you are talking on is almost as bad, and starting to key one in without warning the person that you are talking to is far worse. It gives the person that you are talking to the impression that you are an inconsiderate, ill-mannered lout with a room-temperature I.Q., an impression that is likely to be particularly difficult to overcome as it is probably correct.

Your PDA can certainly substitute for pencil and paper, of course, provided it is booted up and ready to go when you need it. If your batteries are dead, your stylus missing, or even if you have to struggle through a long menu before you can enter the information the person you've called is trying to provide, you can safely bet that you are not making a good impression.

## Calendar of General Membership Meeting of Sunday, April 6, 2008

Call to Order: 10:00 a.m.

Flag Salute

Roll call of Officers

Reading of the Minutes of previous meetings:

General Membership meeting of March 2, 2008

Executive Board meeting of March 16, 2008

Motions passed (unless otherwise noted)

- 1) To loan Dropped member sufficient funds from the Jim Buck Memorial Benevolent Fund to be reinstated for the purpose of returning to work or taking an Honorable Withdrawal by June 30, 2008.
- 2) To loan an injured-on-the-job member sufficient funds from the Jim Buck Memorial Benevolent Fund to be reinstated for the purpose of returning to work or taking an Honorable Withdrawal by September 30, 2008.
- 3) To loan an injured member sufficient funds from the Jim Buck Memorial Benevolent Fund to be reinstated for the purpose of returning to work or taking an Honorable Withdrawal by June 30, 2008.
- 4) To pay one quarter's dues for Greg Bridges in appreciation of his help in organizing two low-budget projects.
- 5) To raise Assistant Business Representative Russell C. Nordstedt's rate of pay to the Basic Key Grip 54-Hour rate.
- 6) That Local 80 shall pay for hotel accommodations for the Delegates to the 2008 District 2 Convention at the The Fairmont San Jose Hotel for 2 nights (June 6 - 7, 2008.).
- 7) That Local 80 shall reimburse reasonable expenses for air fare and for ground travel to and from airports for the Delegates in connection with the District 2 Convention in 2008.
- 8) That Local 80 shall pay each Delegate \$59.00 per diem for 2 days in connection with the District 2 Convention in 2008, minus any per diem paid by District 2 for those days.
- 9) That President J. David Ahuna will be the Delegate-in-Charge of Local 80's delegation to the 2008 District 2 Convention.

Executive Board meeting of April 6, 2008

Secretary - Treasurer's Report

Business Representative's Report

Committee Reports

Communications

Unfinished Business

New Business

Good and Welfare

Adjournment: not later than 12:30 PM

## Classified Advertising

### FOR SALE, LEASE, OR RENT:

4 hood, and 4 side mounts. Best in the movie business. Carl Manoogian, 818-784-1834

**FOR RENT:** 16' Air conditioned Crafts Service truck, fully loaded with 2 frigs., 1 included in sandwich bar, lots of cabinets and counter space, coffee maker, and television. \$450.00/week, \$90.00/day. Call Laban Freeman 818-399-9563 or 818-845-5949

**WANTED:** Used Grip Equipment c-stands, hi-rollers, mombos, combos, carts, sandbags, reflectors, rags, etc. 818-517-9492

**FOR SALE:** Panther Foxy crane. All opts including riding mode, long and short bucket outriggers, Large, small and pony weight buckets, Custom underwater boom section, Fulcrum to Mitchell adapter, Super Mario type weight carts, Wide track wheel adapters and much more. Good cond. rents all the time for \$650+ per day. Great crane for a Key to carry. Fits in the isle of a 10 ton. \$19,500. For info and pics call Tony at 941-809-4704 or email Scott at scott@cinemoves.com

**FOR RENT:** Crafts Services Truck, Loaded Looks great, plus U make money 500 wk last rent for 1200 wk, Call Peter Popp 323-350-3269

**FOR RENT:** Craft Service Truck, Triple sink, all stainless, soda cooler, double traulson, can help with package if needed. Available for long term call 818-437-6956. 661-510-6287

**FOR SALE OR RENT:** 14' Craft Service Truck. 2000 Ford w/low miles in excellent condition. Newly installed Stainless Steel Counter Tops, Cabinets, Walls, Sinks w/ hot & cold running water, Diamond Plate floor, Air Condition, Refrigerated Sandwich Bar, Upright Refrigerator/Freezer, Lift Gate w/stairs & hand rail. \$24,000. Honda Generator additional \$2,500. Call Dave 818-843-5143, cell 818-939-9287.

**WANTED:** New grip and lighting

corp. seeks to buy quality used grip and lighting trucks, empty trucks and trailers and supporting prod. equip. 1st comp. to be co-owned by many of our own Local 80 and 728 brothers! People with no money or equip. can make cash with our company! Also we are looking for people who need warehouse or office space for their gear or company to share an excellent well known location to co-lease with us. We offer a very generous investment plan for those who are interested. For any questions or to be e-mailed the business plan. Call Matt at 323-420-3275

**FOR SALE BY OWNER:** Pine Canyon country living. 22505 Valley View Dr. Tehachapi Ca 93561, 2.5 ac. fenced corner lot. Ready to build. All permitted, engineered, graded pad, well and 10' x 12' well house. Eclectic at corner. 360 degree view. \$139,000. Option to buy additional 2.84 ac. adjoining lot. \$39,000 Ian Momberger 661-822-4339

**FOR SALE:** New 12x silver lamay, 12x gold lamay, 12x S/G checker, 6x S/G checker, all for \$550.00. Taco cart \$350.00 oba. Please call Raul 323-578-2640.

**FOR SALE OR RENT:** Crafts Services truck, 2000 Freightliner fully equipped with stainless steel double door refrigerator, freezer, sandwich bar, sink, diamond plated floors, 4 jockey boxes, 13 KW lowboy generator, Rubbermaid cart, food cart, and coffee cart. Food prep. table, plenty of cabinet and storage space. Must see. Call Darin at 805-217-5716.

**FOR SALE:** Enlouva IIIA remote crane w/ Darby base. Max length 22'6". Phoenix remote crane w/base. Rideable max length 23'10". Max remote head length is 40'. Contact Chris 818-519-7906.

**SCUBA EQUIPMENT FOR SALE:** Diver propulsion vehicles, Dacor Seasprint \$700, DPV Farllon MK7E underwater scooter 2.7mph 400fsw gauge mount and new fast charger, two Amphibico underwater

camera housing with 3 Sony VX1000 DVCAM, 2 HMI lights 20 batteries, 6 charges, 2 color monitors, 4 color filters, 6 diopters, 4 cases, plus extra parts and much more \$5000. Scubapro Thermal Tec Steamer wetsuits, 5mm, Large \$75, and 2mm, Large \$35, Scubapro 2 sets \$600 & mk25 \$150. for each 1st and 2nd stage regs, Contact Charles Simons 310-621-3837

**FOR SALE:** Giraffe Classic Camera Crane (remote 31' & rideable 24'). Complete with 84' aluminum track, new weight carts, brand new 20' custom trailer, tools, and more. \$50,000 OBO. Please call Joe for more details at 818-439-1034

**FOR SALE:** Spider Hi Hat, 4 way level head, 50% off. 213-507-0479

**FOR SALE:** Generator, Honda 7000, 60 amps, Low hours, full tank runs 10 hours. \$2,000.or OBO Call Dave 818-843-5143

**FOR SALE:** '68 Ply Fury, stock new weather stripping, pioneer stereo, runs good. \$5000, OBO 818-786-5797.

**LEGAL SERVICES:** Robert F. Smith, Esq. Criminal, Divorce, Probate. Discount for Local 80 Members. 818-364-0607

Classified Ads can be placed by sending ad information to:

the*eighty*news  
c/o Local 80  
2520 W. Olive Ave.  
Burbank, CA 91505  
Fax to 818-526-0718  
email: mail@iatselocal80.org

or bring ads to the Membership Meeting. All ads must be accompanied by a telephone number of the person who is placing the ad and \$5.00. the*eighty*news reserves the right to edit ads.

Any problem with an ad, please call Kent Jorgensen at 818-526-0700, so future problems can be avoided. Local 80 is not responsible for advertisers' claims.

## Wounded Veterans Get Help Toward Entertainment Jobs

Open letter to all of Local 80 and all IATSE members,

This is an open letter of "Thank- you" to Tom Short. Mr. Short is a true American, who helps Americans. I have just personally witnessed his helping hand of injured American soldiers. On March 13, 2008, I had returned from the Wounded Marine Careers Foundation in San Diego, California, a different person. This training center is set up by a camera man and his wife. They have given their all. It is designed to help Marines and Sailors break into the media, with the help and aid of fantastic people like Mr. Tom Short.(Go to the site and see what he did for your self.)

Here's the story:

You may have seen the piece about the wounded Marines attending a film class. The funding was partly provided by Mr. and Mrs. Bob Woodruff Family Fund Foundation. Bob Woodruff the ABC journalist as you may know had received a traumatic brain injury in Iraq. On March 13, 2008, I had the honor to have met Mrs. Lee Woodruff. The woman has a heart the size of two angels. Mr. and Mrs. Kev & Judith Lombard, created the Wounded Marine Careers (training center) Foundation. Both are real angles (Hebrews 13:2) Here is the request, I am not

asking for a fish, I'm asking for equipment to teach these true American heroes (although they will deny it) how to fish. If you can help with any way such as an open entry level position, any new or used equipment, or even a personal word of encouragement, it would help tremendously. A simple word mentioned would help them. The inaugural class will graduate this coming Thursday, March 20, 2008. I first heard of the "Wounded Marine Careers Foundation" on the news on Saturday evening, March 8, 2008. I e-mailed them later that night, offering my services. By Monday afternoon, I had spoke to Mr. Kev Lombard. Thursday morning, March 13, 2008, I spoke for five hours there. And I am just a Local 80 IATSE grip. Can you imagine, someone of your caliber? I write this letter on behalf of the foundation, unsolicited by the foundation. I want to help my fellow Marines "Get their Shot," so to speak. It just seems like the right thing to do. I have provided all the information and phone numbers and the website to get in touch with the Lombard's Thank you, in advance for your time, and may God bless/ as He did me yesterday.

Michael G. Uva  
Former Marine

<http://www.woundedmarinecareers.org/>  
<http://www.bobwoodrufffamilyfund.org/>

## ONE SMALL CONTRIBUTION CAN MAKE A HUGE DIFFERENCE.



By supporting the Motion Picture & Television Fund with a payroll deduction of just \$1.00 a week, you will help make a difference for thousands of your industry colleagues who are in need. MPTF provides charitable services such as financial assistance, healthcare, counseling, retirement living and senior care to film and television workers regardless of their ability to pay. Please help us take care of our own. Make your payroll pledge today!

For more information call the MPTF Foundation at (818) 876-1925 or [www.mptvfund.org](http://www.mptvfund.org).



## Personal Physician Form

**To (Name of Employer)**

---

In the event that I sustain a job-related illness or injury, I designate my personal physician to provide medical care immediately after the injury, and for the purpose of all related care, as appropriate, for the duration of my treatment for that illness or injury. My physician has agreed to be predesignated. By making this request, I am not waiving my right to immediate, appropriate and adequate emergency medical treatment in instances where my personal physician is unavailable, nor am I waiving my right to be referred to specialists or other providers as necessary.

**Personal Physician:**

---

(physician's name, office, clinic or hospital)

**Address:**

---

---

**Telephone:**

---

**Employee's signature:**

---

**Employee's name (print):**

---

**Date:**

---

**Instructions:** In accordance with the new worker's compensation reform law enacted April 19, 2004, as it amends Labor Code Section 4600, if your employer provides group health coverage, you are allowed to predesignate your primary care physician from your employer-provided group health coverage plan as your personal physician for your workers' compensation medical treatment. **If you predesignate your personal physician, you will be allowed to be treated by this doctor immediately after you are injured. If you fail to predesignate your personal physician, your employer may select a physician for you from the date of injury.**

## Predesignating a Doctor for Worker’s Compensation Treatment

*This article appeared in Issue 130, July 2006.*

Most of us never think who is going to treat us if we get hurt on the job. Recent changes in the Worker’s Compensation laws have made it critical to notify your employer, in writing, of who you want to treat you in the event of a workplace injury.

If you predesignate: You will be allowed to see your personal physician right after you are injured. You may switch doctors later, if necessary. The doctor that you predesignate must have treated you in the past and have your medical records. The doctor must be your Primary Care Physician and must agree to be predesignated. It may be useful to predesignate the doctor’s Medical Group.

If you don’t predesignate: Your employer usually will have the right to choose the doctor who treats you for at least the first 30 days after your employer learns about your injury or illness. You can end up with a doctor who works for the employer or the employer’s insurance company and may not have your best interest in mind.

Remember do this when you are doing your deal

memo or paperwork at the beginning of the show, don’t wait till later it, may be too late. Many employers require their own form so ask for their form. If they don’t have one go to our website [www.iatselocal80.org](http://www.iatselocal80.org) and find a generic form, or call the union and we will fax a form to you. *(Use the form on the facing page.)*

Mahalo Nui Loa,  
J. David Ahuna

*This article has been reprinted for two reasons. First, there have been a couple of incidents where Sisters and Brothers have been injured and wanted to see their own doctor but were denied. Second, we are starting to get back to work after the Writer’s Strike and a number of people are filling out start paperwork.*

*Even if you are in the middle of a job you can fill out the form and turn it in to your employer. Make sure they will accept the form or use a form supplied by the employer. You have to do this before a workplace accident occurs.*

The “Grip friendly” camera movement system

“original”  
**The Slider...™** LLC

2’ Slider  
3’ Slider  
4’ Slider  
6’ Slider  
8’ Slider

Please Contact:  
**(805) 496-5289**  
Panavision Remote Systems  
Please ask for the “original” Slider  
(818) 316-1080

Jerry Giacalone  
(805) 341-2692

Ron Veto  
(818) 344-5284

Slide to: **TheSlider.com.**

@Jud Mackelvy  
Studio1412.com

## Real Estate Corner

### What Is A Pre-Foreclosure & Short Sales?

A Pre-Foreclosure occurs when a home owner is behind on his/her mortgage payments. If the home owner fails to pay back payments plus late fees, any taxes or interests, the trustee, often the title company will file a N.O.D (Notice Of Default) with the County Recorders Office and will start the foreclosure process. In many cases a Foreclosure can be avoided by working with a professional Realtor who is an expert in this field. One of the ways to avoid Foreclosure is called a Short Sale Or Short Pay Off. The owner must qualify for a Short Sale which can be determined by a consultation with a Realtor & approval by the bank. I have helped many of my clients in a Short Sale process by selling there property quickly by relieving the homeowner from a mortgage dept and also save there credit. If you or anyone you know that is currently in a similar situation, please call me for a FREE Consultation. Time is of the essence & it is imperative to act quickly if and when there is a Notice of Default filed against the property. Don't settle for less! Know your rights! Call me & I will be happy to answer any questions that you might have. Again your consultation is Free of charge!

For Union Members, I will Pay The Escrow Fee When I represent You For The Purchase or Sell Of Your Home. *Offer Is Valid At A Successful Close Of Escrow & Some Restrictions May Apply.*

### Attn: Home Owners!

Not All Agents Are Created Equal! Before You List Your Home Make Sure You Know Your Agents Credentials. Call Me For a FREE Market Analysis Of Your Home. Your consultation is absolutely FREE of charge.



**Victor Alebian/Broker/Realtor / Cell: (818) 618-5475**



This Is Not Intended As A Solicitation If You Are Currently Working With Another Agent.

**RELIABLE . REPEATABLE . STABILIZED**

# REMOTES



LOS ANGELES . NEW YORK . CHICAGO . DALLAS . NASHVILLE . MIAMI



www.panavision.com  
818.316.1080

### Local 80 Retiree Rx Co-Payment Reimbursement Plan Update

As of August 1, 2006, when the current Basic Agreement went into effect, the cost of prescription co-payments increased substantially. Despite this, Local 80's officers and membership have decided to continue their voluntary program of reimbursing Local 80 retirees' qualified co-payment costs in accordance with the formula in use prior to the change for another year. Therefore, for prescriptions filled under the new contract, the reimbursements will be as follows:

- The program will fully reimburse the co-payment for a three month supply purchased through the Industry Health Plan mail-in provider (still Medco). Medco co-payments are: \$10 for generic drugs, \$30 for preferred brand drugs, and \$36 for all other brands.
- Retirees who do not use the mail-in service can only get a one-month supply. The program will reimburse only an amount equivalent to the cost of Medco service: \$3.33 for generic, \$10 for preferred-brand drugs, and \$12 for all other brands.

The rest of the policy will also remain in effect for another year:

- Only those retirees that inform the Local of their retirement, and who choose to continue their relationship with Local 80 by remaining current on dues as a Plan #1, Plan #2 or Plan #3 Retiree will be eligible for the program, as will their spouses or domestic partners who are covered by the Industry Health Plan (the retired member must inform the Local in writing of their spouse or partner's name.)
- The program can only accept original receipts less than one year old. (The age of receipts will be measured in relation to the beginning of the quarter in which they are submitted, as determined by the postmark.)
- Co-payment requests will be handled on a quarterly basis. There will be four deadlines for submitting receipts each year: February 1st, May 1st, August 1st and November 1st. Checks will be issued by March 15th, June 15th, Sept 15th, and December 15th. (Submissions received after a deadline will be processed with the next quarter's receipts.)

## Retiree Prescription Co-payment Reimbursement Plan Schedule

Submission Deadline:

February 1st

May 1st

August 1st

November 1st

Reimbursement Date:

March 15th

June 15th

September 15th

December 15th

<b>Local 80 Officers</b>	Secretary-Treasurer	Mike Santoro	Trustees
President	Rick Schunke	Bill Sordal	Tommy Adams
David Ahuna	Executive Board	Gil Valle	Melinda Gordon
Vice President	Jim Chizmar	Eric Whitehead	Fred Perdue
Bob Babin	Pat Daily	Page Williams	Assistant B.A.s
Business Agent	Kent H. Jorgensen	Sergeant-at- Arms	David Ahuna
Thom Davis	Lloyd Moriarity	Chris Adams	Craig Conover
	Russell Nordstedt		Russ Nordstedt

the eighty news	800-994-1080	email: mail@iatselocal80.org
is published by:	818-526-0700 ext. 701	Editor: Kent H. Jorgensen
IATSE Local 80	818-526-0719 fax	IATSE Local 80 Website:
2520 W. Olive Ave. Suite 200		www.iatselocal80.org
Burbank, CA 91505		



c/o Local 80  
2520 W. Olive Ave  
Burbank, Ca 91505

## General Membership Meeting in April 6

### Calendar

#### April

- ◆ 6th, 10:00 am General Membership Meeting
- ◆ 20th, 9:00 am: Executive Board Meeting

#### May

- ◆ 4th, 10:00 am General Membership Meeting
- ◆ 18th, 9:00 am: Executive Board Meeting

**3rd Quarter Dues are Due June 30**