



President Tom Short Retires, Matt Loeb Elected IATSE President

by Kent H Jorgensen

At the July 31, morning session of the IA's mid Summer General Executive Board Meeting, International President Thomas C. Short announced his retirement. After many words of appreciation and thanks for his vision and leadership, the General Executive Board unanimously elected International President Matthew D. Loeb to fill the vacancy.

President Emeritus Short has been a member of the IA for over 40 and the International President since 1994. His stated goals were to make the IA a better organization and to provide the best representation possible for the entire membership. The sentiments expressed by the line of people wishing to speak gives testament to his success at accomplishing his goals.

As President, Short has increased the membership by more than 50% to more than 110,000 members. He has substantially increased the assets of the IA including the purchase of two buildings. As part of the restructuring of the Alliance, Short created five Divisions (Stage Craft, Motion Picture and Television Production, Organizing, Trade Show & Display Work, and Canadian Affairs) to focus attention on more specific concerns of the membership.

Short's leadership has resulted in large increases in the pension and health plans. Also, an increase from two term agreements when he started to nearly 2,000 now has lead to more employment and more working families eligible for benefits.

Short gave due recognition to the people who have loyally supported his efforts. He praised the work of the

General Executive Board, the International Representatives, the Staff, and the Locals for their part in achieving these accomplishments.

Newly installed International President Loeb echoed Short's praise. President Loeb added, "I owe a huge debt of gratitude to Tom Short who made desperately needed institutional changes that will allow me to continue to build on a solid foundation. We are well positioned to meet the challenges of the future."

Loeb has been an IA member since 1989. In 2002 he became an International Vice President. He was the Division Director of Motion Picture and Television Production. His aggressive organizing and bargaining policies have resulted in more than 1,000 term agreements in motion pictures, television, music videos, and commercials. International Vice President Mike Miller was appointed to replace Loeb as Division Director.

Before finishing up the agenda items of the meeting, Loeb talked a little about the direction he wanted to go. He said he had been reading the International's Constitution and By Laws. Article One, Section 2. states the purpose of the Alliance. He paraphrased: To achieve, by organization and mutual endeavor, the improvement of the conditions of the membership of the Union.

Loeb added, "I remain convinced that the interests of IATSE members are best protected when we use all of the resources gained through the unity and coordination of our locals and members throughout the United States and Canada."

Calendar

Aug: No General Membership Meeting

Aug 17, 9:00 am: Executive Board Meeting

Sept: No General Membership Meeting

Sept 1: Labor Day Holiday; Offices Closed

Sept 14, 9:00 am: Executive Board Meeting

Sept 28, Family Picnic

4th Quarter Dues are Due Sept 30

Call the accounting office to determine how much you owe

IN MEMORIAM

Fred C. Russell:	Born: 01/06/14	Obligated: 03/02/37	Died: 06/29/08
Gaylin Schultz:	Born: 01/01/26	Obligated: 10/05/47	Died: 07/01/08
Scott A. Smith:	Born: 07/04/61	Obligated: 02/23/96	Died: 04/22/08
Earl Ritchie	Born: 07/19/1921	Obligated: 01/06/63	Died: 07/22/08

Members' names are announced in this space upon the receipt of official notification of death. Official notification generally means an original death certificate or a report from the Motion Picture Industry Pension and Health Plans.







VER SALES, INC.
2509 North Naomi St.
Burbank, CA. 91504
(818) 567-3000 fax: (818) 567-3018
"Over 30 years in the entertainment industry"

   	<p>Aircraft Cable Beam Clamps Block & Falls Bungee Cord Cable Assemblies Camera Tape Carabiners Chain Chain Bags Chain Motors Cheseboros Coated Cable Crosby Clips Daisy Chains</p>	<p>Doughty Clamps Electrical Tape Eyebolts Felco Cutters First Aid Supplies Flashlights Gaffers Tape Horizontal Lifelines Knives Manila Rope Mtn. Climbing Rope Multiline II Nicopress Pipe Clamps</p>	   
     	<p>Pony Clamps Pro Master Rope Sash Cord Safety Cables Shackles Snaps Spansets Stage Set Steel Slings Trick Line Turnbuckles Velcro Web Slings</p>	<p>Rigging • Fall Protection • Hardware • Safety • Rescue Equipment</p> <p>See us on the web at www.versales.com and www.versafety.com</p>	

IATSE Local 80 Family Picnic

September 28

Call the Local for Tickets

GO ELECTRIC: Get the *eighty* news Online
 Send an email to mail@iatselocal80.org and ask to be put on the list



Motion Picture &
Television Equipment

Model 23 Sectional JIB

6 to 21 feet... In 10 minutes

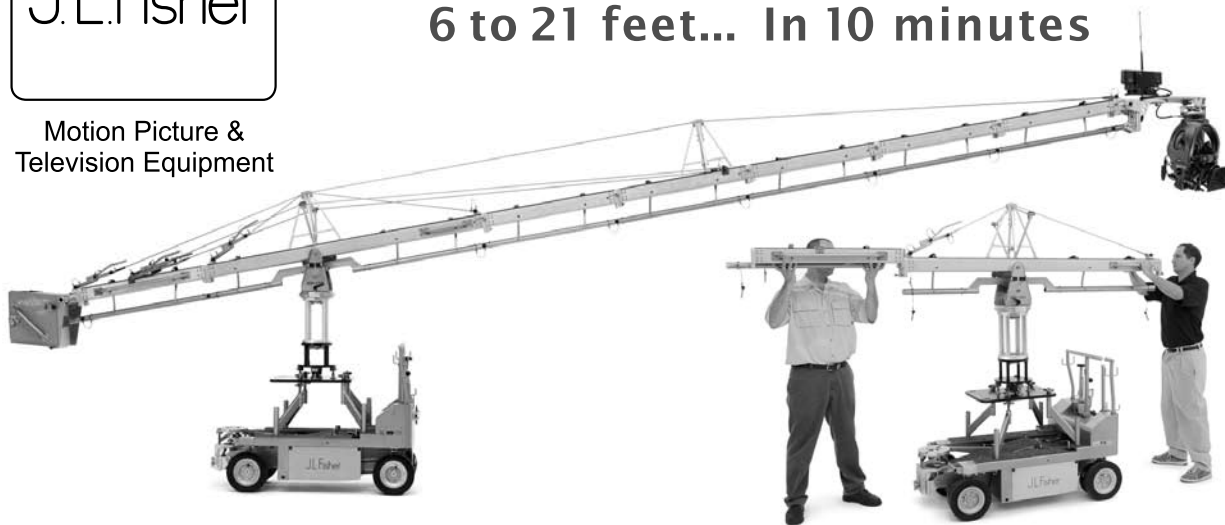

3 foot increments from 6' (1.83m) to 21' (6.4m)

Max payload 131 lbs. (58 kg) @ 21'

"J.L. Fisher products are proudly made in the U.S.A."

J.L. Fisher, Inc. 1000 Isabel Street, Burbank, CA 91506 U.S.A.

J.L. Fisher, GmbH Emil-Hoffmann-Str. 55-59 50996 Köln, Germany

Tel: (818) 846-8366 Fax: (818) 846-8699

Tel: +49 2236 3922 0 Fax: +49 2236 3922 12

Web: www.jlfisher.com e-mail: info@jlfisher.com

Web: www.jlfisher.de e-mail: info@jlfisher.de

CHAPMAN/LEONARD

STUDIO EQUIPMENT, INC. 

CRANES ARMS BASES REMOTE SYSTEMS DOLLIES PEDESTALS

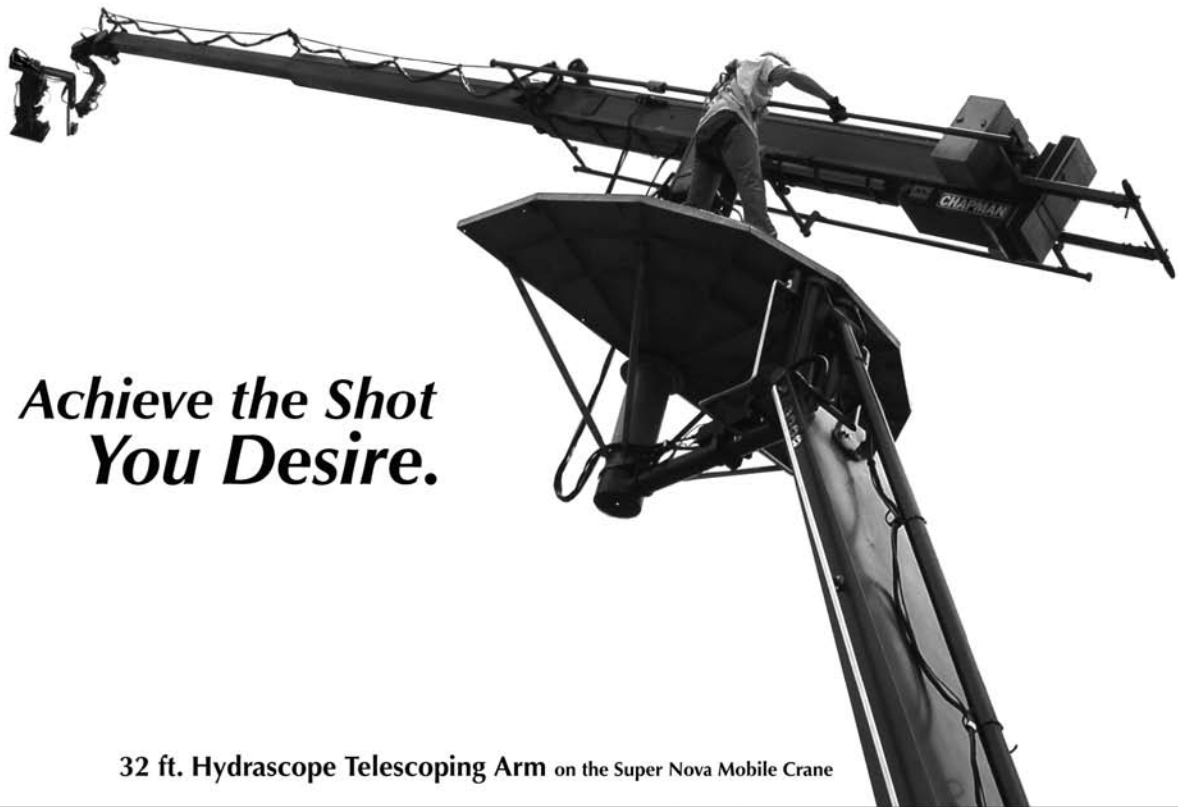

*Achieve the Shot
You Desire.*

32 ft. Hydrascope Telescoping Arm on the Super Nova Mobile Crane



SUPER NOVA on *Martian Child*



HUSTLER IV



LENNY ARM II PLUS on *Eight Below*

LA (888) 883-6559 TX (888) 758.4826 FL (888) 337-8243 Canada (866) 848-2602 UK (888) 883-6559

© Chapman/Leonard Studio Equipment, Inc.

Try our Sound Stage in Orlando, Florida

www.chapman-leonard.com

From the Desk of the Secretary-Treasurer

The Local's Call Stewards spend a great deal of their time transferring callers to someone who will be able to answer their questions. Questions about either paying money to, or getting money from, the Local go to Accounting. Wage or working condition questions are transferred to the Business Representatives.

A surprising number of questions don't get transferred, though, because they have to do with the Callboard itself:

Q: "Do I have to put myself on the Available List if I prefer to find my own work?"

A: Absolutely not: you are required by Local 80's Constitution and Bylaws to keep the Local informed of when, where and for whom you work, but you are not obligated to be listed as Available.

Q: "I called and left a voicemail message saying that I was laid off, but when I called back a few days later I was not on the Available List; why not?"

A: The most likely reason is that you didn't ask to be placed on the Available List. Because members are not required to list themselves as Available, and often don't want to be, the Call Stewards will fill in your work history, but not list you as available for work unless you specifically ask to be listed.

Q: "I specifically requested that my name be placed on the Available List, so why isn't it there?" (This question tends to be asked rather loudly and rudely.)

A: There are many reasons why your name might not be on the Available List:

You may be either Dropped or Suspended for non-payment of dues: the computer will not allow your name to be placed on the Available List in either case. If your name was already on the List when your status changed to Suspended, the computer will automatically remove your name. (It doesn't go back on automatically, though, so be sure to ask the Call Steward to list you as Available after you've paid your dues and been reinstated.)

You may not have responded quickly enough to a page or voicemail: you have a maximum of four hours to respond before you are considered to be unavailable. (This does not mean that a job will be held for you for four hours. The Call Steward is going to keep trying to fill the call; the first member to respond gets the job.)

The Call Steward may have misheard your name and placed someone else on the List, or may have been swamped with incoming calls and forgotten you in the rush.

For these reasons, and too many other possibilities to enumerate, it is a very good idea to call back the day after you ask to be placed on the Available List, just to make sure that your name is really there, and to call every few days thereafter to make sure that your name is still there.

Q: "If my Skills List not filled in will I still be called for work?"

A: Yes, but you are likely to be among those called last: when potential employers call the Local they almost always ask for people with specific skills. The Call Stewards will call available members with the appropriate skills listed first. Only if those members turn the call down will unskilled members (or members whose skills aren't listed) be called. (Of course, if the employer doesn't ask for someone with a specific skill, the Call Stewards will simply go down the Available List in order until someone takes the job. You are certainly welcome to gamble on this, but it's really not a particularly good bet.)

Q: "I don't do any of the things listed on the Skills/Preferences list for my Craft. Why isn't my specialty listed?"

A: If your specialty is not on the list, call and request that it be added. (In addition to making the Callboard work better for you, you may help pinpoint areas where Local 80 should be working for additional contractual protection in the division of labor, thus helping every other member of Local 80 who works in your Craft.)

Q: "Why are there two Available Lists for each of Local 80's Crafts?"

A: The second Available List is actually called the Ready List. Ready Lists are started fresh each morning, and are used as a fallback to avoid having to release Permit calls. When the time available to fill a call is very short, the Call Stewards will call people who have phoned in that morning to say that they are ready to go to work immediately. They do not call them in the order that they put themselves on the Ready List, but will first call those with the necessary skills listed who live closest to the job. (Remember, if the Call Stewards can't fill those positions quickly, the company is free to hire one or more Permits to fill the available spots.)

Q: "Do I have to call in each day in order to get work through the Local?"

A: No, but your chances are certainly going to improve if you do. As anyone who has worked in the back lot Crafts for a while knows, our employers

continued on page 6

August, 2008

the *eightynews*

continued from page 5

are not noted for thinking ahead. This means that the Local tends to get last minute calls for workers much more frequently than calls that allow a lot of time to fill, which means that members on the daily Ready Lists are more likely to be called than those who are not.

For Local 80's members, the Callboard is a tool to augment your job hunting capacity. Like any other tool, it requires some effort on the part of the user. If you are willing to put forth that effort then the Callboard can become an invaluable resource.

If you are one of the rather large number of

members who has never used the Callboard to find work, you should consider this: no matter how long your contact list is, you can't possibly know every single person who might hire you. Nor can you reasonably expect that everyone who might hire you will invariably know when you are available, nor that when they are in a hurry they will call you just on the chance that you might be.

Being on the Ready List is an excellent way to make new contacts. Even in the remote chance you never meet someone who might hire you, you are practically bound to meet someone that you will one day want to hire.

NBC Universal **GRIP**

- Automated inventory system
- Loading and holding bays
- Expanded inventory
- Steel Deck, Scaffolding
- Large supply of motors and box truss
- Scene Dock
- Rigging crews available on-lot and off-lot
- Ability to accommodate additional needs for key grip rental packages
- Canvas Room
- Pre-loaded 5 and 10 ton grip trucks

818.777.2291 • 800.892.1979 THE FILMMAKERS DESTINATION WWW.NBCUNI.COM/STUDIO

NBC UNIVERSAL
MEDIA WORKS
MEDIA TECHNOLOGY & OPERATIONS

NBC BURBANK UNIVERSAL STUDIOS NBC NEW YORK

CraneShot
by Jan

Technocrane Services

with

* **SCORPIO Remote Head**
2- Axis or 3- Axis

* **SCORPIO Stabilized Head**

Call 310-577-1185 or e-mail: pia@craneshot.us

for additional information and quotes

You could win a Harley Davidson Dyna Street Bob



Join your I.A.T.S.E. Local in supporting a raffle for a new Harley Davidson Dyna Street Bob
Proceeds will Benefit the Motion Picture & Television Fund (MPTF)

Tickets are \$20.00 each

The Drawing will be on September 28, 2008
Don't miss the chance to support MPTF and Help Take Care of Our Own!
Purchase Tickets from Your Local Union or Steward

YOU COULD BE RIDING A DYNA STREET BOB

Limited ticket quantities available, the more tickets that you buy the better your chances to win.
you do not have to be present to win. All fees, registration, taxes, etc., will be the responsibility of the
winner.



Real Estate Corner

SFV Home Sales Trending Up

Homes are selling in the SFV with activity gradually picking up on month to month basis and the number of properties in escrow suggesting the trend will continue through the coming month's as buyers take advantage of the housing slow down and foreclosures. If this trend continues, it suggests that we may have passed the bottom of this cycle with the worst behind us. There were total of 853 transactions in escrow at the end of March 2008 up 12.4% from February. Condominium sales were also up 38.5% from February. It will take some time for foreclosure to work its way through the system and only then will prices stabilize. Negotiating with a motivated seller, whose home is priced competitively from the beginning, may yield a superior bargain and a faster escrow than a foreclosure will. Plus the condition of the home in a traditional purchase instead of foreclosure which typically are sold AS IS offering zero opportunity to negotiate for repairs or concessions in price. At the current pace of sales, the inventory represents a 12.7 month supply, clearly a buyers market but well below the 20 plus month supply seen during the early 90's

Attn: Home Owners!

Not All Agents Are Created Equal! Before You List Your Home Make Sure You Know Your Agents Credentials. Call Me For a **FREE** Market Analysis Of Your Home.



Victor Alebian
 Broker Associate
 Cell: (818) 618-5475
 Email:
 brokerrealestate@sbcglobal.net



This is not intended as a solicitation if you are currently working with another agent.

matthews
 STUDIO EQUIPMENT
TECHNOLOGY THAT COMPLEMENTS YOUR IMAGINATION.



DIGITAL & CHROMAKEY
 BLUE/GREEN SCREEN

www.msegrip.com
OVER 1400 GRIP & LIGHTING CONTROL PRODUCTS

© Copyright 2007. Matthews Studio Equipment, Inc. All rights reserved.

matthews
 STUDIO EQUIPMENT
TECHNOLOGY THAT COMPLEMENTS YOUR IMAGINATION.

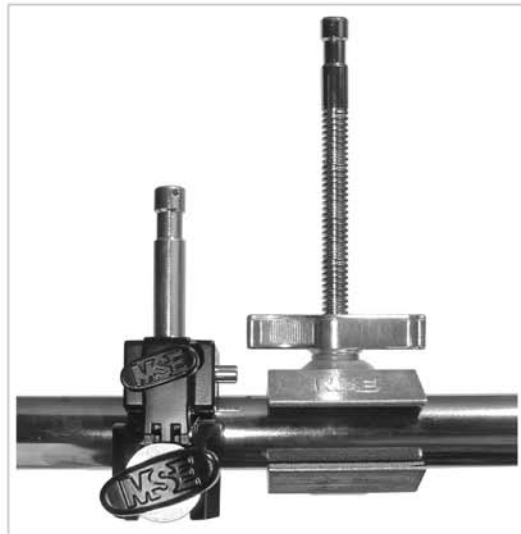

CLAMPS

www.msegrip.com
OVER 1400 GRIP & LIGHTING CONTROL PRODUCTS

© Copyright 2007. Matthews Studio Equipment, Inc. All rights reserved.

Classified Advertising

FOR SALE, LEASE, OR RENT: 4 hood, and 4 side mounts. Best in the movie business. Carl Manoogian, 818-784-1834

FOR RENT: Crafts Services Truck, Loaded Looks great, plus U make money 500 wk last rent for 1200 wk, Call Peter Popp 323-350-3269

FOR RENT: Craft Service Truck, Triple sink, all stainless, soda cooler, double traulson, can help with package if needed. Available for long term call 818-437-6956. 661-510-6287

FOR SALE OR RENT: Crafts Services truck, 2000 Frieghtliner fully equipped with stainless steel double door refrigerator, freezer, sandwich bar, sink, diamond plated floors, 4 jockey boxes, 13 KW lowboy generator, Rubbermaid cart, food cart, and coffee cart. Food prep. table, plenty of cabinet and storage space. Must see. Call Darin at 805-217-5716.

FOR SALE: Enlouva IIIA remote crane w/ Darby base. Max length 22'6". Phoenix remote crane w/base. Rideable max length 23'10". Max remote head length is 40'. Contact Chris 818-519-7906.

SCUBA EQUIPMENT FOR SALE: Diver propulsion vehicles, Dacor Seasprint \$700, DPV Farllon MK7E underwater scooter 2.7mph 400fsw gauge mount and new fast charger, two Amphibico underwater camera housing with 3 Sony VX1000 DVCAM, 2 HMI lights 20 batteries, 6 charges, 2 color monitors, 4 color filters, 6 diopters, 4 cases, plus extra parts and much more \$5000. Scubapro Thermal Tec Steamer wetsuits, 5mm, Large \$75, and 2mm, Large \$35, Scubapro 2 sets S600 & mk25 \$150. for each 1st and 2nd stage regs, Contact Charles Simons 310-621-3837

FOR SALE: Giraffe Classic Camera Crane (remote 31' & rideable 24'). Complete with 84' aluminum track, new weight carts, brand new 20'

custom trailer, tools, and more. \$50,000 OBO. Please call Joe for more details at 818-439-1034

FOR SALE: Spider Hi Hat, 4 way level head, 50% off. 213-507-0479

FOR SALE: Generator, Honda 7000, 60 amps, Low hours, full tank runs 10 hours. \$1,500 or OBO Call Dave 818-939-9287

FOR SALE OR RENT: 16' air conditioned Crafts Service truck; fully loaded w/ 2 frigs, 1 included in the sandwich bar, lots of cabinets and counter space, coffee maker, and television. \$11, 000 OBO, \$450/week, \$90.00/day. Call Laban Freeman @ 818-399-9563 or 818-845-5949

FOR SALE: 2-12'X30' Digi Green Screens, New, perfect condition. Made by Forepeak. Sewn edge with grommets. \$705.00 for both. Contact Darren 213-910-0169 in Burbank.

FOR RENT: 45' production trailer. Full length jockey boxes, side door w/ steps, air ride, new rubber and Alcoa rims, 7' aluminum articulated lift gate. Adjustable shelves with office and locking cabinets. Load your gear for feature or T.V. I also have a very clean Kenworth cabover tractor to pull the trailer. Can make a package deal if you need both the tractor and trailer. Call Jerry Enright, 818-903-0750.

FOR SALE: 10 ton 1991 Freightliner with 350 Cummins engine, only 430,000 miles and in excellent running condition, 28ft. box w/shelving and a 6ft. Interlift gate. Call 213-447-2067 for info and pricing.

FOR SALE: Crafts Service Truck, \$22,000, Call Jeff Winn 818-841-0043

FOR RENT: Crafts Services trailer, fully equipped and clean! Comes with cappuccino machine, coffee maker, fridge, freezer, a/c unit, popcorn and hot dog machines, tv/dvd, oven, baskets/containers, tables, and a

generator. Available for long and short term. Call Mike at 310-963-1369.

WANTED: Used Grip Equipment c-stands, hi-rollers, mombos, combos, carts, sandbags, reflectors, rags, etc. 818-517-9492

FOR SALE: 14' Craft Service Truck. 2000 Ford w/low miles in excellent condition. Newly installed Stainless Steel Counter Tops, Cabinets, Walls, Sinks w/ hot & cold running water, Diamond Plate floor, Air Condition, Refrigerated Sandwich Bar, Upright Refrigerator/Freezer, Lift Gate w/ stairs & hand rail. \$24,000. Call Dave 818-939-9287

FOR SALE: Motor Boat, 2001 Wellcraft, 2600 Martinique, 27' 5" length, aft cabin, electric stove, microwave, VHF, Df, GPS, radar, vacum flush head, CD player, sleeps 6 \$39,000 or best offer. Call Barry 805-432-7696.

FOR SALE: 27 pullys, rated to 650#, 25 3/8" shackles. Cost \$445, sell for \$200. Call Mike, 818-294-8838.

Classified Ads can be placed by sending ad information to:

Local 80

attn: Kent, *theeightynews*
2520 W. Olive Ave., Suite 200
Burbank, CA 91505

Fax to 818-526-0711

email: mail@iatselocal80.org

or bring ads to the Membership Meeting. All ads must be accompanied by a telephone number of the person who is placing the ad and \$5.00. *theeightynews* reserves the right to edit ads.

Any problem with an ad, please call Kent Jorgensen at 818-526-0700, so future problems can be avoided. Local 80 is not responsible for advertisers' claims.

The "Grip friendly" camera movement system

"original"

The Slider...TM LLC

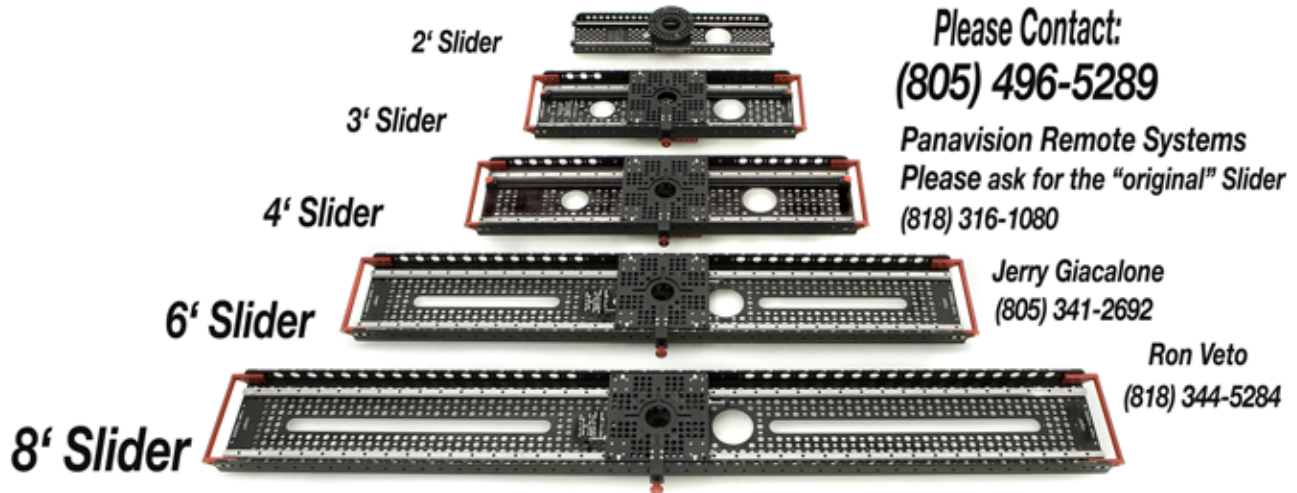

Slide to: **TheSlider.com.**

@Jud Mackelvy
Studio1412.com

LOS ANGELES

NEW YORK

CHICAGO

DALLAS

NEW ORLEANS

MIAMI

NASHVILLE

and our newest location
SHREVEPORT
 with TEAM SHARK

TECHNOCRANE

STRADA

LIBRA HEAD

SCORPIO HEAD

HOT HEAD

POWER POD

CAMERA SLIDERS

Ask about our newest equipment

20' SUPERTECHNO

PRECISION TRACK for 20' & 30' SUPERTECHNOS

MOTORIZED TECHNO BASE

PANAMOUNT

818.316.1080
www.panavision.com

*Local 80 Members Are Now Eligible for
Membership in the
Twentieth Century Fox Federal Credit Union*

*For more information call Melissa at 310-432-2341 or go to
www.foxcredit.com*

***THE NAGGING WON'T STOP UNTIL YOU
TAKE THE RIGGING SAFETY CLASS!!!!***

The Safety Pass: 818-502-9932 or www.csatf.org

NOTE TO KEY GRIPS and CRAFTS SERVICE: The Key Grip/Crafts Service department heads are responsible for determining that there are no members of his/her crew in violation of Article XV Section VI of the Local Eighty Constitution and may be charged with such responsibility before the Local Eighty Executive Board should violations be found under Article 1 Section 1 of Local Eighty's By-Laws.

**Retiree Prescription Co-payment
Reimbursement Plan Schedule**

Submission Deadline:	Reimbursement Date:
February 1st	March 15th
May 1st	June 15th
August 1st	September 15th
November 1st	December 15th

Local 80 Officers	Secretary-Treasurer	Mike Santoro	Trustees
President	Rick Schunke	Bill Sordal	Tommy Adams
David Ahuna	Executive Board	Gil Valle	Melinda Gordon
Vice President	Jim Chizmar	Eric Whitehead	Fred Perdue
Bob Babin	Pat Daily	Page Williams	Assistant B.A.s
Business Agent	Kent H. Jorgensen	Sergeant-at- Arms	David Ahuna
Thom Davis	Lloyd Moriarity	Chris Adams	Craig Conover
	Russell Nordstedt		Russ Nordstedt

the eighty news	800-994-1080	email: mail@iatselocal80.org
is published by:	818-526-0700 ext. 701	Editor: Kent H. Jorgensen
IATSE Local 80	818-526-0719 fax	IATSE Local 80 Website:
2520 W. Olive Ave. Suite 200		www.iatselocal80.org
Burbank, CA 91505		



c/o Local 80
2520 W. Olive Ave
Burbank, Ca 91505

No General Membership Meeting in Aug

Calendar

August

- ◆ No General Membership Meeting
- ◆ 17th, 9:00 am: Executive Board Meeting

September

- ◆ No General Membership Meeting
- ◆ 14th, 9:00 am: Executive Board Meeting

4th Quarter Dues are Due Sept 30