



Dues Deferment Enacted to Help Deflect Writer's Strike Effects

The Executive Board of the Local passed the following motion to help the membership with the aftermath of the Writer's strike.

That I.A.T.S.E. Local 80, in recognition of the hardships experienced by its membership due to the strike by the Writers Guild Of America against the A.M.P.T.P., shall adopt a policy regarding the payment of quarterly dues for the time period set forth in Nos. 3 & 4 following, and

Additionally, in recognition that the Local does not have the authority to waive or forgive dues owed, and must remain in compliance with the Constitution of the Local and the I.A.T.S.E., the term deferred in this instance shall mean the payment of monies that are normally and customarily owed only to the Local, which are to be paid at a future date in installments, and

That such deferment shall be allowed to all members who apply and are qualified as given below; and

1) For all qualified members of this Local, dues in excess of \$50.00 per quarter shall be deferred until a date as set forth in 3 and 4 below, and

That, a qualified member shall be defined as a member of this Local who was current on all financial obligations to the Local through the fourth quarter of 2007. (This is not to include any fines, or fees, of which the member is not aware or which is on appeal), and the members earnings do not exceed \$10,000 in the preceding quarter, and

That, thirty days prior to the end of the deferral period the Local shall advise the member of the total amount held against their account (owed), and the minimum amount to be paid and the dates and intervals in which payments must be made, and

2) That, the dues deferral policy shall begin on the first day of the second quarter (April 1) of 2008, and

3) That, the dues deferral policy shall be terminated 210 days (seven months) following the ratification of the agreement between the WGA and the AMPTP, and

4) That, members who have had their dues obligation deferred shall be obligated to make payments deferred amount in one hundred dollar (\$100) increments in conjunction with their quarterly dues, and

5) That, the member shall supply and be obligated to update the following information to the Local on a form to be supplied by the Local which shall include:

- a) The current address of the member
- b) The current phone number of the member (Home, or Cell)
- c) The last date of employment of the member
- d) The name of the last employer, along with the Payroll Company
- e) The availability status of the member must be recorded with the Local 80

f) In order to remain eligible the member must notify the Local of any changes of employment status within 24 hours of such change.

Calendar

Mar 2, 10:00 am: General Membership Meeting

Mar 9, 2:00 am: Time Change (Spring Forward)

Mar 16, 9:00 am: Executive Board Meeting

Mar 21: Good Friday Holiday

April 6, 10:00 am: General Membership Meeting

April 20, 9:00 am: Executive Board Meeting

2nd Quarter Dues are Due March 31

Call the accounting office to determine how much you owe

IN MEMORIAM

Hugo Elizondo: Born: 08/08/63 Obligated: 08/17/92 Died: 02/15/08

Members' names are announced in this space upon the receipt of official notification of death. Official notification generally means an original death certificate or a report from the Motion Picture Industry Pension and Health Plans.







VER SALES, INC.
2509 North Naomi St.
Burbank, CA. 91504
(818) 567-3000 fax: (818) 567-3018
"Over 30 years in the entertainment industry"







Aircraft Cable
 Beam Clamps
 Block & Falls
 Bungee Cord
 Cable Assemblies
 Camera Tape
 Carabiners
 Chain
 Chain Bags
 Chain Motors
 Chesebros
 Coated Cable
 Crosby Clips
 Daisy Chains

Doughty Clamps
 Electrical Tape
 Eyebolts
 Felco Cutters
 First Aid Supplies
 Flashlights
 Gaffers Tape
 Horizontal Lifelines
 Knives
 Manila Rope
 Mtn. Climbing Rope
 Multiline II
 Nicopress
 Pipe Clamps

Pony Clamps
 Pro Master
 Rope
 Sash Cord
 Safety Cables
 Shackles
 Snaps
 Spansets
 Stage Set
 Steel Slings
 Trick Line
 Turnbuckles
 Velcro
 Web Slings







Rigging • Fall Protection • Hardware • Safety • Rescue Equipment

See us on the web at www.versales.com and www.versafety.com

The Newsletter: Looking for a Few Good Words

by Kent H. Jorgensen

The newsletter has been around for over 12 years. It was started to improve the communications between the members of the Local. The newsletter has changed and gotten bigger over the years, and many times members think that only a few people are allowed to write articles or letters. The reason only a few people write to the newsletter is they are the only people who do write.

The policy of the newsletter has always been to put letters from member in the paper. The criteria has been that anything can be talked about, but no personal attacks are allowed. Letters will be published anonymously if the writer wishes, but the editor will only allow letters where he knows the author, but then withholds the name if asked. Letters are sometimes edited to try and make the English a little more formal, but there is an effort to try and maintain the voice and sentiment of the author.

There have been times when letters have not ap-

peared. These are mostly because of personal attacks, length of the letters, or the English is too difficult to deal with.

Articles and pictures are also welcome. New products, sharing techniques, or remember people are all things of interest to members of the Local.

Many people don't believe they can write a good article. Even if you are challenged in the writing department, sending in an idea with facts and information can be used to write an article.

The newsletter also runs a classified section. Just email the information you want to appear, send five dollars to the Local, and your ad will appear for three issues.

So, if you would like to see some more variety or voice an issue, write something for the *eighty* news. Send contributions of about 500 word to mail@iatselocal80.org. Include your name, and a way to get a of you incase there is some change that needs to be made.

J.L.Fisher

Motion Picture &
Television Equipment

Model 23 Sectional JIB

6 to 21 feet... In 10 minutes

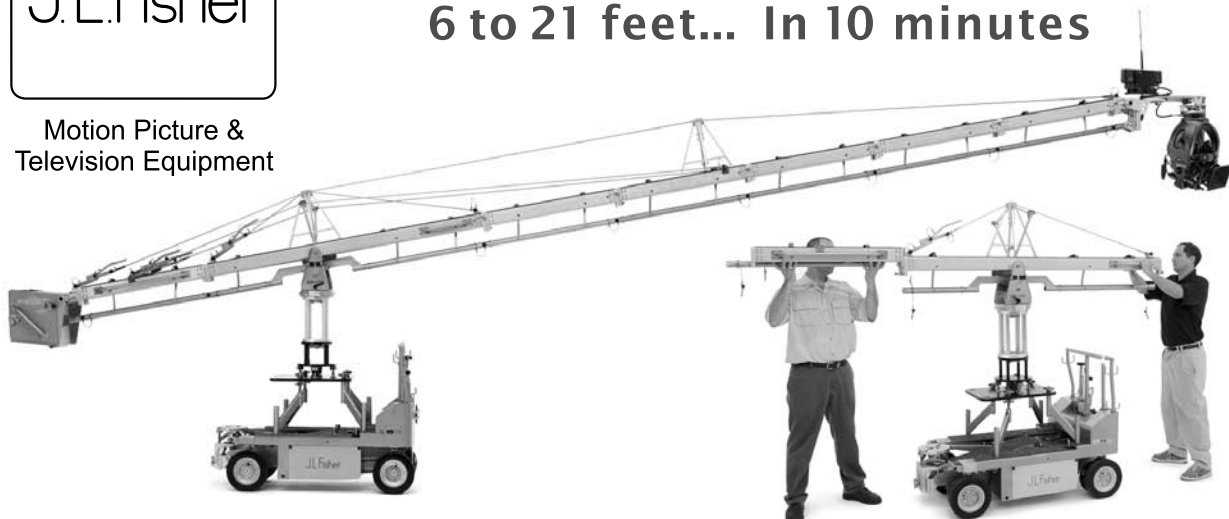

3 foot increments from 6' (1.83m) to 21' (6.4m)

Max payload 131 lbs. (58 kg) @ 21'

"J.L. Fisher products are proudly made in the U.S.A."

J.L. Fisher, Inc. 1000 Isabel Street, Burbank, CA 91506 U.S.A.

J.L. Fisher, GmbH Emil-Hoffmann-Str. 55-59 50996 Köln, Germany

Tel: (818) 846-8366 Fax: (818) 846-8699

Tel: +49 2236 3922 0 Fax: +49 2236 3922 12

Web: www.jlfisher.com e-mail: info@jlfisher.com

Web: www.jlfisher.de e-mail: info@jlfisher.de

CHAPMAN/LEONARD

STUDIO EQUIPMENT, INC. 

CRANES ARMS BASES REMOTE SYSTEMS DOLLIES PEDESTALS

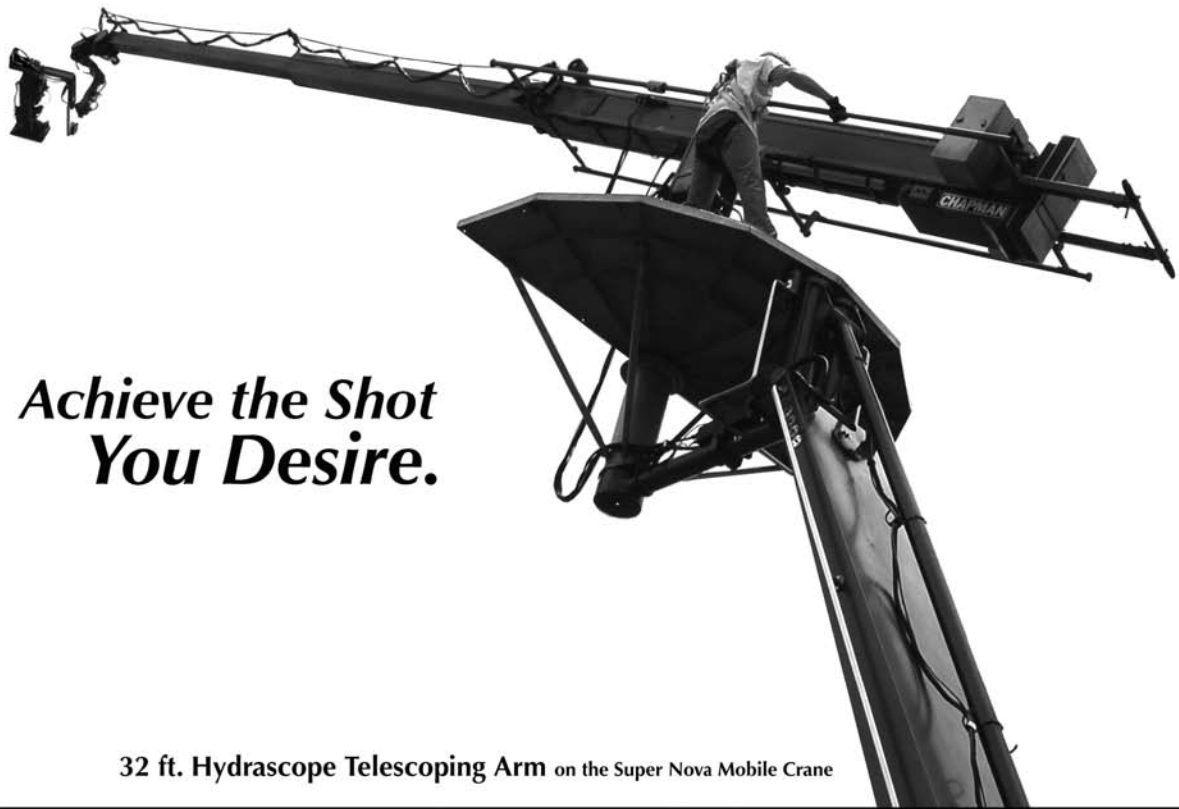

*Achieve the Shot
You Desire.*

32 ft. Hydrascope Telescoping Arm on the Super Nova Mobile Crane



SUPER NOVA on *Marian Child*



HUSTLER IV



LENNY ARM II PLUS on *Eight Below*

LA (888) 883-6559 TX (888) 758.4826 FL (888) 337-8243 Canada (866) 848-2602 UK (888) 883-6559
 © Chapman/Leonard Studio Equipment, Inc. *Try our Sound Stage in Orlando, Florida* www.chapman-leonard.com

Labor Community Services Spring Project

Come and join us in bringing a spring full of joy
to children in homeless and abuse shelters!

The Los Angeles County Federation of Labor, AFL-CIO Community Services,
its Alumni Association
and United Way of Greater Los Angeles

We'll visit homeless and abused children in shelters, bringing the Easter Bunny to deliver baskets filled with your donations of new clothing, hygiene items, small toys, and candy.

The distribution of the baskets will be on March 20 and 21.
For additional information, call Ericka at 213-985-2000.

Contributions can be brought to the General Membership Meeting
or to the Local. Financial Contributions can be sent to:
Labor Community Services, 2130 West James M. Wood Blvd,
Los Angeles, Ca 90006.



<p>M.E.L. Cinema Crane Inc.</p> <p><i>Giraffe</i></p>  <p>Michael E. Listorti Dolly Grip 818-559-2261 818-601-0125</p>	<p>Divers Association Meeting After the General Membership Meeting Sunday, April 6</p> 
---	--

<p>NBC Universal GRIP</p> 	<ul style="list-style-type: none"> Automated inventory system Loading and holding bays Expanded inventory Steel Deck, Scaffolding Large supply of motors and box truss Scene Dock Rigging crews available on-lot and off-lot Ability to accommodate additional needs for key grip rental packages Canvas Room Pre-loaded 5 and 10 ton grip trucks <p>818.777.2291 • 800.892.1979 THE FILMMAKERS DESTINATION WWW.NBCUNI.COM/STUDIO</p> <p>NBC & UNIVERSAL MEDIA WORKS NBC BURBANK UNIVERSAL STUDIOS NBC NEW YORK MEDIA TECHNOLOGY & OPERATIONS</p>
--	--

From the Desk of the Secretary-Treasurer

Second-quarter dues (still \$200.00, if you had the very good fortune to earn enough during the Writers' strike to have to pay full dues) are due not later than midnight, March 31, 2008. If you intend to pay by credit card, please call in a few days ahead of the deadline; your credit card bill will arrive on the same day whether you pay your dues at the last minute or not, so you lose nothing by paying a little early. On the other hand, helping to spread Accounting's workload out a bit by calling in early will gain you friends, and will greatly reduce your chances of being kept on hold for twenty minutes (or more) while other last-minute callers are being helped. (By the way, just a probably futile note for the incurably dense: since calls are handled in the order that they are received, hanging up and calling back puts you back at the end of the phone queue, not at the front of the line. Calling me, the Call Stewards or the Business Agents to complain that you've been put on hold for twenty minutes several times merely serves to give us a good laugh at your expense, not to gain you any sympathy. Next time, call before the last minute.)

Because of the Writers' strike, there are a great many members who owe less than full dues, including a few who paid full dues in advance. If you are one of that paid-in-advance group, don't panic; you can easily have your excess dues credited forward toward future quarters. All it takes is a phone call to the Accounting Department and your signature on a couple of cards that they will mail to you, and you are all set.

For those who didn't pay in advance, but who earned less than \$10,000 in the first quarter of 2008 and who were current on dues on December 31, 2007, there is a Dues Deferral Application form in this issue of *The Eighty News* that will allow you to defer all but \$50.00 of your second-quarter dues for seven months. (The program is not for the first quarter: you need to have those dues paid before you are eligible for deferral of your second-quarter dues. There was a form in the February issue, also: if you mailed that one to the Local before the last week of March, you will need to submit a new one.)

Please don't waste your time (or that of the Accounting Department staff) by mailing in the Dues Deferral Application form if you were not current on dues on December 31st even if you became current later: you are not eligible under that program.

If you didn't pay your first quarter dues because

you wanted to save your money as long as possible during the strike, it is now time to pay them. If you go beyond the end of the quarter without paying first quarter dues, your membership will be suspended, even if you haven't worked a single day since your dues were last current.

With the Writers' strike now a thing of the past there will be a temptation (at least for those who were lucky enough to have not have suffered complete financial devastation during the strike) to let their financial guard down. Don't fall for it.

The effects of the strike on the work situation in our industry will linger on for an unknown period. Sadly, that period is far more likely to be measured in months than in days or weeks. There will be some work soon, of course, just as there was some work during the strike, but full employment is probably not just around the corner.

It is important that you actively hunt for whatever work may develop, rather than just waiting to be called. Make sure that you are still on the Available List, and call in each morning to get on the Ready List for the day.

Whatever money you are able to earn should go to paying off debt, then into savings against the possibility of another work stoppage.

As appalling as it is to contemplate, the possibility of an Actors' strike being called this year simply can not be safely ignored.

The Screen Actors Guild has not taken any official position of which I am aware at the time of this writing, but there has been public talk from at least one of their officers that would indicate that SAG is not going to merely settle for a contract that is based on the framework established by what the Writers were finally able to achieve based on the Directors' excellent groundwork.

Until the Actors have signed a new contract, do whatever it takes to avoid letting yourself get caught with your savings down.

There are various aid programs still available to Local 80's members, whether your financial distress was caused entirely by the Writers' strike, or by some other cause entirely. One of those programs may fit your situation perfectly.

Call the Local and ask for help if you need it. Don't miss out on whatever assistance may be available to you because you were too bashful to pick up the phone and ask for it.

Calendar of General Membership Meeting of Sunday, March 2, 2008

Call to Order: 10:00 a.m.

Flag Salute

Roll call of Officers

Reading of the Minutes of previous meetings:

General Membership meeting of February 3, 2008

Executive Board meeting of February 10, 2008

Motions passed (unless otherwise noted)

- 1) To cease the monthly publication of the Dropped and Suspended Lists.
- 2) To publish a Suspended List in the February, May, August and October hardcopy issues of The Eighty News only.
- 3) To loan an injured member sufficient money from the Jim Buck Memorial Benevolent Fund to become current on dues for the purpose of returning to work or taking an Honorable Withdrawal by June 30, 2008.
- 4) To loan an injured member sufficient money from the Jim Buck Memorial Benevolent Fund to become current on dues for the purpose of returning to work or taking an Honorable Withdrawal by March 30, 2008.
- 5) To loan an injured member sufficient money from the Jim Buck Memorial Benevolent Fund to become current on dues for the purpose of returning to work or taking an Honorable Withdrawal by June 30, 2008.
- 6) To loan an injured member sufficient money from the Jim Buck Memorial Benevolent Fund to become current on dues for the purpose of returning to work or taking an Honorable Withdrawal by June 30, 2008.
- 7) To loan an injured member sufficient money from the Jim Buck Memorial Benevolent Fund to become current on dues for the purpose of returning to work or taking an Honorable Withdrawal by March 30, 2008.
- 8) To loan a member sufficient money from the Jim Buck Memorial Benevolent Fund to become current on dues for the purpose of returning to work or taking an Honorable Withdrawal by March 30, 2008.
- 9) To loan a member sufficient money from the Jim Buck Memorial Benevolent Fund to become current on dues for the purpose of returning to work or taking an Honorable Withdrawal by March 30, 2008.
- 10) To contribute \$1,000.00 to the AFL-CIO Community Services Spring Program for the benefit of homeless, abused and underprivileged children.
- 11) To purchase 1,500 Local 80 "I SURVIVED THE WRITERS STRIKE 2007-2008" t-shirts.
- 12) To add white-ink transparent logo decals to the promotional items inventory.
- 13) The Executive Board shall adjourn not later than 15 minutes prior to General Meetings for the purpose of swearing in new members.

Executive Board meeting of March 2, 2008

Secretary - Treasurer's Report

Business Representative's Report

Committee Reports

Communications

Unfinished Business

New Business

Good and Welfare

Adjournment: not later than 12:30 PM

JSF - HOWS

RALEIGH STUDIOS MANHATTAN BEACH

GROCERY DELIVERY & CATERING

A Complete Source For All Your Crafts Service Needs

Accurately Shopped Grocery Items Delivered to Your Stage or Location

Breakfast to 2nd Meals

Outsourced Meals and Specialty Items

Westside/South Bay and Our New North Hollywood Commissary

On Site BBQs, Sushi, and More.

EVENING ORDER LINE (6:30 PM - 3:30 AM) 310-793-0284

CAFÉ ORDER (SAME DAY ORDERS AND REQUESTS) 310-727-2783

FAX ORDER LINE 310-802-6838

For questions please contact John Scavo at 310-864-6235 or email JohnScavo@yahoo.com

JSF-HOWS

The Café at Raleigh Studios
1600 Rosecrans Blvd. Bldg. 5A
Manhattan Beach, CA 90266



HOWS Granada Hills HOWS Pasadena HOWS Malibu HOWS NoHo HOWS Torrance

The "Grip friendly" camera movement system

"original"

The Slider...™ LLC

2' Slider



3' Slider



4' Slider



6' Slider



8' Slider

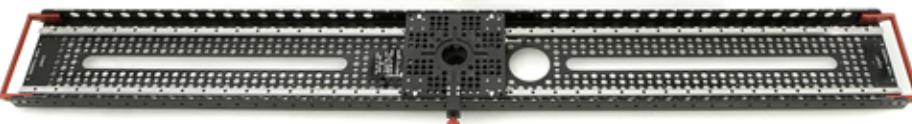

Please Contact:

(805) 496-5289

Panavision Remote Systems

Please ask for the "original" Slider

(818) 316-1080

Jerry Giacalone

(805) 341-2692

Ron Veto

(818) 344-5284

Slide to: **TheSlider.com.**

@Jud Mackelvy
Studio1412.com

Classified Advertising

FOR SALE, LEASE, OR RENT: 4 hood, and 4 side mounts. Best in the movie business. Carl Manoogian, 818-784-1834

FOR RENT: 16' Air conditioned Crafts Service truck, fully loaded with 2 frigs., 1 included in sandwich bar, lots of cabinets and counter space, coffee maker, and television. \$450.00/week, \$90.00/day. Call Laban Freeman 818-399-9563 or 818-845-5949

WANTED: Used Grip Equipment c-stands, hi-rollers, mombos, combos, carts, sandbags, reflectors, rags, etc. 818-517-9492

FOR SALE: Panther Foxy crane. All opts including riding mode, long and short bucket outriggers, Large, small and pony weight buckets, Custom underwater boom section, Fulcrum to Mitchell adapter, Super Mario type weight carts, Wide track wheel adapters and much more. Good cond. rents all the time for \$650+ per day. Great crane for a Key to carry. Fits in the isle of a 10 ton. \$19,500. For info and pics call Tony at 941-809-4704 or email Scott at scott@cinemoves.com

FOR RENT: Crafts Services Truck, Loaded Looks great, plus U make money 500 wk last rent for 1200 wk, Call Peter Popp 323-350-3269

SCUBA CLASSES: PADI classes available include Open Water, Adv. Open Water, Emergency First Responder, Rescue and Divemaster. PADI specialties available include Underwater Navigator, Deep Diver, Drysuit and Enriched Air (Nitrox). Also available are DAN Oxy provider, Adv. Oxy Provider, AED, and SSI Open Water Diver classes. Contact Steve: 310-864-2000.

FOR RENT: Craft Service Truck, Triple sink, all stainless, soda cooler, double traulson, can help with package if needed. Available for long term call 818-437-6956. 661-510-6287

FOR SALE: 32' trailer 96 96, spring ride with level lift gate-

needs batteries, with side door, no jockeys, Call 323-662-8390 or email william131@mac.com for more information

FOR SALE: 14' Craft Service Truck. 2000 Ford w/low miles in excellent condition. Newly installed Stainless Steel Counter Tops, Cabinets, Walls, Sinks w/ hot & cold running water, Diamond Plate floor, Air Condition, Refrigerated Sandwich Bar, Upright Refrigerator/Freezer, Lift Gate w/ stairs & hand rail. \$24,000. Honda Generator additional \$2,500. Call Dave 818-843-5143

WANTED: New grip and lighting corp. seeks to buy quality used grip and lighting trucks, empty trucks and trailers and supporting prod. equip. First company to be co-owned by many of our own Local 80 and Local 728 brothers! People with no money or equip. can make cash with our company! Also we are looking for people who need warehouse or office space for their gear or company to share an excellent well known location to co-lease with us. We offer a very generous investment plan for those who are interested. For any questions or to be e-mailed the business plan. Call Matt at 323-420-3275

FOR SALE: Refrigerator. Double Doors, Stainless Steel, Microprocessor control and Settings. Delfield model 6051-S. \$500 OBO. Call Kathy 818-843-5143

FOR SALE BY OWNER: Pine Canyon country living. 22505 Valley View Dr. Tehachapi Ca 93561, 2.5 ac. fenced corner lot. Ready to build. All permitted, engineered, graded pad, well and 10' x 12' well house. Eclectic at corner. 360 degree view. \$139,000. Option to buy additional 2.84 ac. adjoining lot. \$39,000 Ian Momberger 661-822-4339

FOR SALE: New 12x silver lamay, 12x gold lamay, 12x S/G checker, 6x S/G checker, all for \$550.00. Taco cart \$350.00 oba. Please call Raul 323-578-2640.

FOR SALE OR RENT: Crafts Services truck, 2000 Frieghtliner fully equipped with stainless steel double door refrigerator, freezer, sandwich bar, sink, diamond plated floors, 4 jockey boxes, 13 KW lowboy generator, Rubbermaid cart, food cart, and coffee cart. Food prep. table, plenty of cabinet and storage space. Must see. Call Darin at 805-217-5716.

FOR SALE: Enlouva IIIA remote crane w/ Darby base. Max length 22'6". Phoenix remote crane w/base. Rideable max length 23'10". Max remote head length is 40'. Contact Chris 818-519-7906.

SCUBA EQUIPMENT FOR SALE: Diver propulsion vehicles, Dacor Seasprint \$700, DPV Farllon MK7E underwater scooter 2.7mph 400fsw gauge mount and new fast charger, two Amphibico underwater camera housing with 3 Sony VX1000 DVCAM, 2 HMI lights 20 batteries, 6 charges, 2 color monitors, 4 color filters, 6 diopters, 4 cases, plus extra parts and much more \$5000. Scubapro Thermal Tec Steamer wetsuits, 5mm, Large \$75, and 2mm, Large \$35, Scubapro 2 sets S600 & mk25 \$150. for each 1st and 2nd stage regs, Contact Charles Simons 310-621-3837

Classified Ads can be placed by sending ad information to:

theeightynews
c/o Local 80
2520 W. Olive Ave.
Burbank, CA 91505
Fax to 818-526-0718
email: mail@iatselocal80.org

or bring ads to the Membership Meeting. All ads must be accompanied by a telephone number of the person who is placing the ad and \$5.00. **theeightynews** reserves the right to edit ads.

Any problem with an ad, please call Kent Jorgensen at 818-526-0700, so future problems can be avoided. Local 80 is not responsible for advertisers' claims.

Real Estate News

Home sales in San Fernando Valley plunged during October as buyers waited to see what will happen in the home loan market and for resale to fall. Single Family home sales throughout San Fernando Valley during October plunged 54.1% compared to the prior year. At the current pace of sales, the inventory represents a 16.0 month supply, the highest total since early 1990's and an indicator of a pure buyer's market. It's not surprising that buyers hesitate to jump into a market that actually is the best market in many years, however waiting may not mean they will get a better deal down the road. The interests rates are still very attractive and a buyer with a good credit and a reasonable down payment will get a loan, a wide selection, negotiating power and a great value. The Real Estate market has been through downturns before and this one too eventually will turn around. But waiting in a hope of timing the bottom of the market typically means a buyer will miss the best opportunities.

How would you like the bank to pay for your closing costs? Sounds impossible? I can assure you that it's not. No gimmicks, no hidden costs, no surprises! Call & ask me about our NO FEE MORTGAGE PLUS PLAN & I will be happy to explain it to you. I have helped many of my first time home buyers by saving them thousands of dollars in closing costs & I can do the same for you.

Attn: Home Sellers!

Not All Agents Are Created Equal! Before You List Your Home Make Sure You Know Your Agents Credentials. Call Me For a FREE Market Analysis Of Your Home. and Don't forget to ask me about my BIG CASH REBATE Program!



Victor Alebian/Broker/Realtor / Cell: (818) 618-5475



This Is Not Intended As A Solicitation If You Are Currently Working With Another Agent.

RELIABLE . REPEATABLE . STABILIZED

REMOTES



LOS ANGELES . NEW YORK . CHICAGO . DALLAS . NASHVILLE . MIAMI



www.panavision.com

818.316.1080

Local 80 Retiree Rx Co-Payment Reimbursement Plan Update

As of August 1, 2006, when the current Basic Agreement went into effect, the cost of prescription co-payments increased substantially. Despite this, Local 80's officers and membership have decided to continue their voluntary program of reimbursing Local 80 retirees' qualified co-payment costs in accordance with the formula in use prior to the change for another year. Therefore, for prescriptions filled under the new contract, the reimbursements will be as follows:

- The program will fully reimburse the co-payment for a three month supply purchased through the Industry Health Plan mail-in provider (still Medco). Medco co-payments are: \$10 for generic drugs, \$30 for preferred brand drugs, and \$36 for all other brands.
- Retirees who do not use the mail-in service can only get a one-month supply. The program will reimburse only an amount equivalent to the cost of Medco service: \$3.33 for generic, \$10 for preferred-brand drugs, and \$12 for all other brands.

The rest of the policy will also remain in effect for another year:

- Only those retirees that inform the Local of their retirement, and who choose to continue their relationship with Local 80 by remaining current on dues as a Plan #1, Plan #2 or Plan #3 Retiree will be eligible for the program, as will their spouses or domestic partners who are covered by the Industry Health Plan (the retired member must inform the Local in writing of their spouse or partner's name.)
- The program can only accept original receipts less than one year old. (The age of receipts will be measured in relation to the beginning of the quarter in which they are submitted, as determined by the postmark.)
- Co-payment requests will be handled on a quarterly basis. There will be four deadlines for submitting receipts each year: February 1st, May 1st, August 1st and November 1st. Checks will be issued by March 15th, June 15th, Sept 15th, and December 15th. (Submissions received after a deadline will be processed with the next quarter's receipts.)

Retiree Prescription Co-payment Reimbursement Plan Schedule

Submission Deadline:

February 1st

May 1st

August 1st

November 1st

Reimbursement Date:

March 15th

June 15th

September 15th

December 15th

Local 80 Officers	Secretary-Treasurer	Mike Santoro	Trustees
President	Rick Schunke	Bill Sordal	Tommy Adams
David Ahuna	Executive Board	Gil Valle	Melinda Gordon
Vice President	Jim Chizmar	Eric Whitehead	Fred Perdue
Bob Babin	Pat Daily	Page Williams	Assistant B.A.s
Business Agent	Kent H. Jorgensen	Sergeant-at- Arms	David Ahuna
Thom Davis	Lloyd Moriarity	Chris Adams	Craig Conover
	Russell Nordstedt		Russ Nordstedt

the eighty news	800-994-1080	email: mail@iatselocal80.org
is published by:	818-526-0700 ext. 701	Editor: Kent H. Jorgensen
IATSE Local 80	818-526-0719 fax	IATSE Local 80 Website:
2520 W. Olive Ave. Suite 200		www.iatselocal80.org
Burbank, CA 91505		



c/o Local 80
2520 W. Olive Ave
Burbank, Ca 91505

General Membership Meeting in Mar 2

Calendar

March

- ◆ 2nd, 10:00 am General Membership Meeting
- ◆ 16th, 9:00 am: Executive Board Meeting

April

- ◆ 6th, 10:00 am General Membership Meeting
- ◆ 20th, 9:00 am: Executive Board Meeting

2nd Quarter Dues are Due March