



Rigging Practices Highlight Safety Pass Class

by Kent H. Jorgensen

Of all the jobs performed by Grips rigging is probably the one done the most often. As Grips we are professional riggers. For many of us the challenges of rigging are the reason we are Grips. The Rigging Safety class started out aimed at “rock n roll” type rigging, but the class revealed how much the theories and philosophies of rigging reach into nearly every part of our job.

Like riggers in other industries we follow practices that have been handed down over many centuries. Most of the practices taught in the class are things our members already know. It is stuff we have done for years. It is common sense. The weight of things we lift, hold, and move may not be as heavy as lifts made in shipyards or on construction sights, but the practices are the same. Even a c-stand follows similar theories as cantilevered cranes. Applying these practices can help us avoid problems.

One practice is understanding the rigging system you are going to use. Whether it is a c-stand holding a flag with a sandbag counterbalance or a truss system using multiple chainmotors to lift and position lighting and set elements knowing the system is important.

One system that poses a potential problem for riggers is the manufacture wood I-beam system. This system is intended to replace floor joists and support a plywood on top of the beams. It is a great system for floors. But, at times, these beams are being used in place of large pieces of lumber (4x12) in warehouse stages and other load bearing applications. What riggers have to keep in mind is the wood I-beams are not intended for side loading, and some kind of bracing or other means needs to be used to resist the torsional

force acting on the system.

Inspection is another practice vital for a successful rig. Poorly maintained, malfunctioning, or broken equipment can often be the cause of problems. When talking about inspection, many believe that it is a complicated, expensive process. But, most equipment just needs to be looked at, touched, or listened to. If you know the system being used problems will begin to make themselves apparent if you pay attention to the system.

Inspections not only have to include the rigging equipment, but any other equipment that interacts with the rigging. A truss rigged for lighting may require a substantial amount of power for the lights. The movement of the truss can cause an abrasion to the power cables. The abrasion can work through the insulation, contact metal, and cause a short which can take a bite out of the chain of a chainmotor or other part of the load system.

Planning is probably the most important practice to follow. Evaluate the different conditions, equipment, and consequences of the job in choosing how you are going to perform the rig. This evaluation can be fast in cases of a common situation which has been encountered before, or it may take time to think it out, research, and plan a solution. The planning may require seeking out assistance from a more experienced brother or sister or from a professional like an engineer.

As a professional apply good practices to the rigging you do.

November 30 is the deadline for the Rigging Safety Class. Go online at csatf.org or call 818-502-9932 to sign up for a class.

Calendar

Oct 5, 10:00 am: General Membership Meeting

Oct 5, 12:30 pm: Hands On, Basic Rigging

Oct 19, 9:00 am: Executive Board Meeting

Nov 2, 10:00 am General

Membership Meeting

Nov 4: Election Day. VOTE!

Nov 16, 9:00 am: Executive Board Meeting

Nov 27-28: Thanksgiving Day Holiday; Offices Closed

1st Quarter Dues are Due Dec 31

Call the accounting office to determine how much you owe

IN MEMORIAM

Allan H. Mylander:	Born: 06/17/44	Obligated: 10/02/66	Died: 09/13/08
Kevin S."Max" Bartlett:	Born: 10/11/72	Obligated: 10/17/96	Died: 07/17/08

Members' names are announced in this space upon the receipt of official notification of death. Official notification generally means an original death certificate or a report from the Motion Picture Industry Pension and Health Plans.







VER SALES, INC.
2509 North Naomi St.
Burbank, CA. 91504
(818) 567-3000 fax: (818) 567-3018
"Over 30 years in the entertainment industry"

    	<p>Aircraft Cable Beam Clamps Block & Falls Bungee Cord Cable Assemblies Camera Tape Carabiners Chain Chain Bags Chain Motors Cheseboros Coated Cable Crosby Clips Daisy Chains</p> <p>Doughty Clamps Electrical Tape Eyebolts Felco Cutters First Aid Supplies Flashlights Gaffers Tape Horizontal Lifelines Knives Manila Rope Mtn. Climbing Rope Multiline II Nicopress Pipe Clamps</p> <p>Pony Clamps Pro Master Rope Sash Cord Safety Cables Shackles Snaps Spansets Stage Set Steel Slings Trick Line Turnbuckles Velcro Web Slings</p>	    
---	--	---

Rigging • Fall Protection • Hardware • Safety • Rescue Equipment

See us on the web at www.versales.com and www.versafety.com

A Remembrance of Scott Robinson

by Gerald Riggs

It has been nearly a year since Brother Scott Robinson died, but a number of those who loved him wished to add this small remembrance of him.

Scott was a well respected member of Local 80 since 1977. He was the Key Grip on such films as Rendition, Memoirs of a Geisha, LA Confidential, and The Insider.

He also gave generously of his time and talents to children and the community. He help in local theater productions and with the Club Scouts. Scott himself was an Eagle Scout which pushed his interest as an outdoors man.

Many admired Scott. He had a great passion for

life and faced the adversities of life with courage.

Scott lost his fight with lung cancer surrounded by his family in his home in Palos Verdes Estates on December 29, 2007. He is survived by his wife of

22 years, Jane, his son Michael, daughter Caitlin, mother Leslie Caccamise and siblings Jan Lamonica, Todd Robinson, Martha Welch, George Caccamise, Tess Luna, and Trudy Carey.

For more information on Scott's life go to www.scottmichaelrobinson.net. There is also a fund set up for the family: The friends of: Scott Robinson

Family Trust, 2644 Via Carrillo, Palos Verdes, CA 90274, TAX I.D. # 916 538 339



Motion Picture & Television Equipment

Model 23 Sectional JIB

6 to 21 feet... In 10 minutes

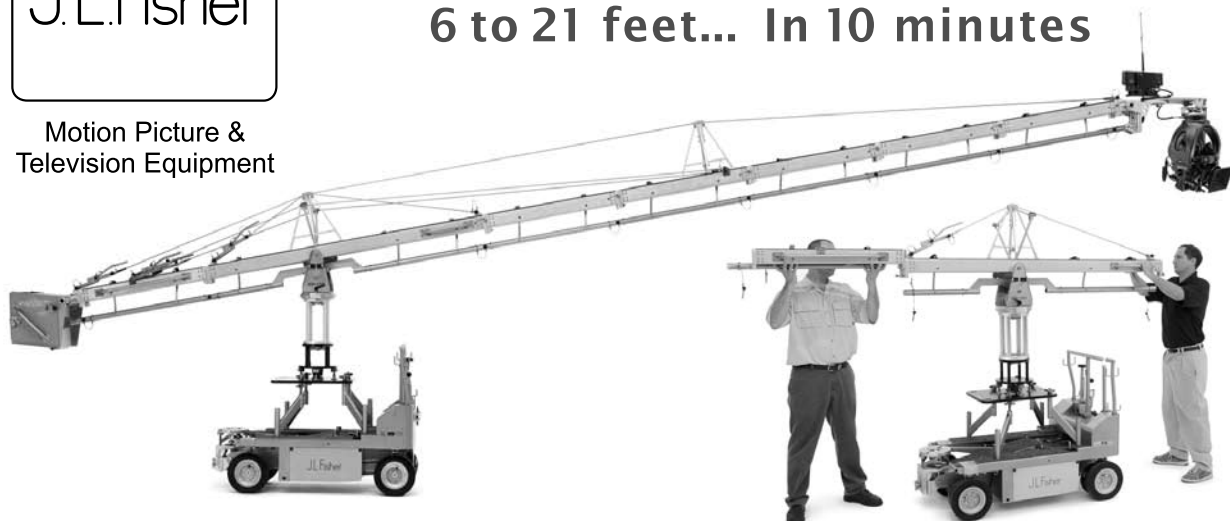

3 foot increments from 6' (1.83m) to 21' (6.4m)

Max payload 131 lbs. (58 kg) @ 21'

"J.L. Fisher products are proudly made in the U.S.A."

J.L. Fisher, Inc. 1000 Isabel Street, Burbank, CA 91506 U.S.A.

J.L. Fisher, GmbH Emil-Hoffmann-Str. 55-59 50996 Köln, Germany

Tel: (818) 846-8366 Fax: (818) 846-8699

Tel: +49 2236 3922 0 Fax: +49 2236 3922 12

Web: www.jlfisher.com e-mail: info@jlfisher.com

Web: www.jlfisher.de e-mail: info@jlfisher.de

CHAPMAN/LEONARD

STUDIO EQUIPMENT, INC. 

CRANES ARMS BASES REMOTE SYSTEMS DOLLIES PEDESTALS

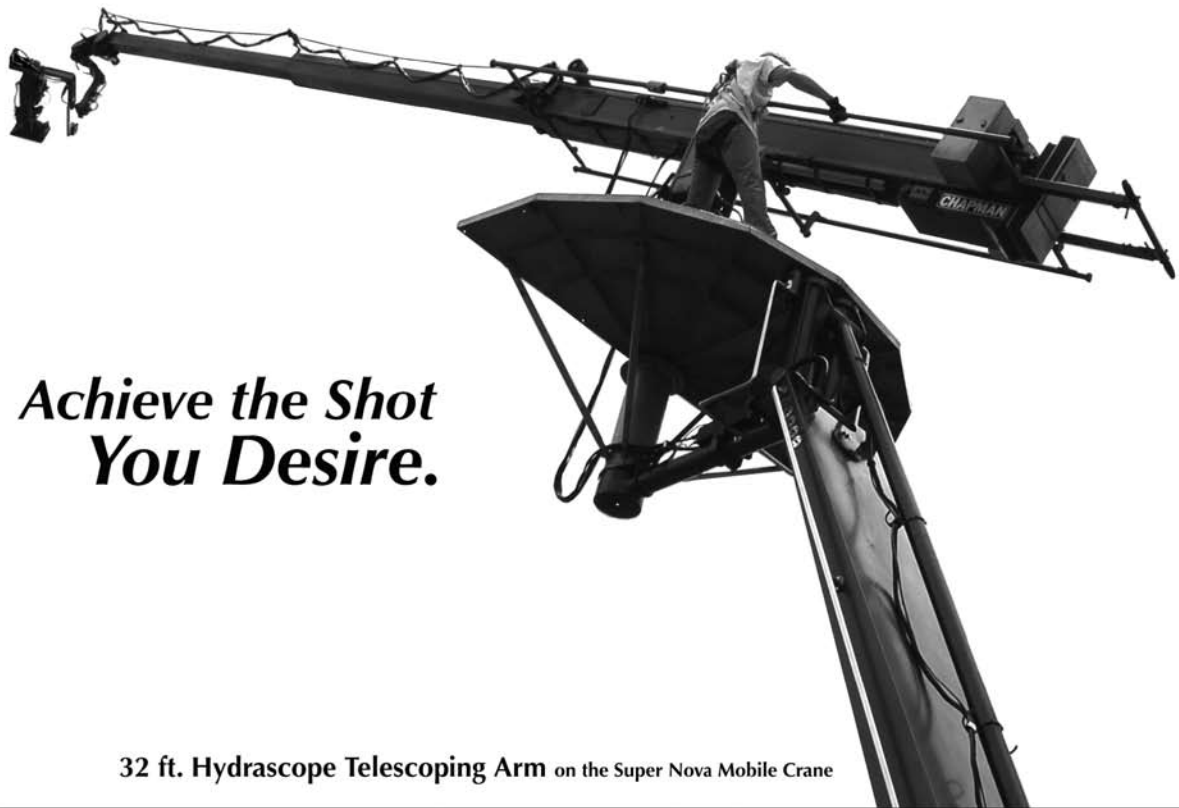

*Achieve the Shot
You Desire.*

32 ft. Hydrascope Telescoping Arm on the Super Nova Mobile Crane



SUPER NOVA on *Martian Child*



HUSTLER IV



LENNY ARM II PLUS on *Eight Below*

LA (888) 883-6559 TX (888) 758.4826 FL (888) 337-8243 Canada (866) 848-2602 UK (888) 883-6559

© Chapman/Leonard Studio Equipment, Inc.

Try our Sound Stage in Orlando, Florida

www.chapman-leonard.com

From the Desk of the Secretary-Treasurer

Although the uninitiated might never imagine it, one of the most frustrating aspects of being the Secretary-Treasurer of Local 80 is simply the fact that it is impossible to tell how much it costs to actually carry out the business of the Local. This is not because of any shortcoming in the Local's accounting systems, record management or bookkeeping, all of which are more than adequate to the conventional tasks of tracking both income and expenditures.

No, the difficulty is caused by something that I suspect relatively few other organizations have to deal with, or would consider a problem if they did: volunteerism.

"Rick, you've got to be kidding!" I can hear the echo of protesting voices even before anyone else sees this column, "How could people volunteering their time to work for the Local possibly be bad for the Local?"

Well, first, let me point out that I didn't say that volunteered time, work, or even materials was bad for the Local; I said that it is frustrating for the Secretary-Treasurer. There is a big, and very important, difference.

It must be clear to any but the deliberately obtuse that Local 80 (by which I really mean all of us; the thousands of members that comprise our Local) clearly benefits in many ways from the huge amount of volunteered time and effort that so many freely give. The frustrating thing for a Secretary-Treasurer (I am not the first Secretary-Treasurer to point this out) is that there is really no way to quantify those benefits.

This isn't too much of an issue when it comes to things like the Picnic or other social affairs, because the cost to our treasury of these important but non-critical events is essentially whatever the cash outlay totals. If the level of volunteerism should drop, the effects would certainly be appreciable to event attendees, but the most critical functions of the Local, contract negotiation and enforcement, organizing, and member representation, would not be hampered. When it comes to items that do directly affect those critical functions, though, the issues raised become far more important.

For many years, and even more so now than in the past, Local 80 has had the felicitous "problem" of being unable to determine the actual cost of carrying out its critical functions simply because our employees work more hours than they are paid for. A lot more.

The business agents are the biggest culprits; I

often get calls at five-thirty or six in the morning, well before official office hours start at 8:00 a.m., from members who want to know what time a Business Representative is going to get in. The answer is usually that at least some have already come in. When the official close of business comes at 6:00 p.m., the chances are that at least some of them will still be here. Quite often, it will still be the same ones. They might have had to go out to a half-dozen locations to deal with problems during the day, but will have come back to be sure that there's nothing that can't wait before they finally go home.

On top of doing their own work of contract enforcement and organizing, the Local's Business Representatives unhesitatingly step in to help with taking dues by telephone during the last and first few days of each quarter. They also help at the Callboard, so that the Call Stewards can still take breaks even when I am too swamped to take over for them.

These are not trivial benefits to the Local. If the Business Representatives weren't voluntarily working longer-than-reasonable hours to make sure that everything that needs to be done is being done, the Local would need to hire another full-time Business Representative, as well as several part-time clerks several times each year.

On top of the other work that they do for us, they make sure that the various groups or companies that rent Local 80's stage or conference rooms have whatever they need to assure that they'll want to rent from Local 80 again. They help to make sure that the building is cleaned and maintained properly. They serve on various committees, and act as delegates to other Labor organizations. They attend Labor classes to make sure that they are always up to date on the latest information and techniques that they might be able to use to help Local 80's members.

The Safety and Training Representative is another culprit in making it impossible to figure out the real cost of carrying out the business of the Local. He, too, works an unreasonable number of hours. When not at his desk answering members' calls about the many safety or training issues that come up at the hundreds of venues that Local 80's members work in, he might be out in the field investigating accidents, or serving as a delegate to other Labor or safety-related organizations. If he isn't in one of those places, and he isn't helping the Business Representatives down on the stage, he is working on *The Eighty News*, an originally voluntary task that has essentially become a part of the Safety Representative's job.

The problem extends to the Office Manager, as

continued from page 5

well. These days I seldom work the fifteen-plus hour shifts that I did the first year or two after I took over as Secretary-Treasurer, but when I do I invariably find that our Office Manager is still working after hours. She has also fallen into the bad habit that the rest of us have, of taking coffee breaks and meal breaks at her desk, despite being frequently reminded that, as their Lot Steward, she is setting a bad example for the clerks. At least the clerks haven't started doing it, though they sometimes have to be reminded to go home after the ends of their shifts.

The Call Stewards are not immune to

volunteerism, either. They frequently come in and help each other on their (theoretical) days off.

So, as the Secretary-Treasurer, do I find it frustrating that I can't accurately figure out the real cost of conducting the business of the Local? Yes, I do.

On the other hand, as a dues-paying member of our Local, am I grateful that, because of the extraordinary willingness of my fellow employees here at the Local's offices to do far more than they are asked (or paid) to do, my dues don't have to be high enough to cover that cost? Yes, Brothers and Sisters, I most definitely am.

American Red Cross

1(800) GIVE LIFE

1(800) 448-3543

www.redcross.org

Questions? Call toll-free: 1 (800) 214-0441

E-mail: bloodquestions@usa.redcross.org



The Straight Shoot'r is a unique jib-arm combined with a linear Z-axis sliding camera mount.

It offers you effortless floating steadycam-like moves, straight-line dolly moves, and everything in between.

For rental information: (818) 609-8310
or: www.StraightShootr.com



Technocrane Services

with

* SCORPIO Remote Head
2- Axis or 3- Axis

* SCORPIO Stabilized Head

Call 310-577-1185 or e-mail: pia@craneshot.us

for additional information and quotes

Calendar of General Membership Meeting of Sunday, October 5, 2008

Call to Order: 10:00 a.m.

Flag Salute

Roll call of Officers

Reading of the Minutes of previous meetings:

General Membership meeting of June 1, 2008

Executive Board meeting of June, 2008

Motions passed (unless otherwise noted)

- 1) To pay a reinstatement fee on behalf of a Suspended #3 Retiree due to unusual circumstances.
- 2) To loan a Suspended member on Workers Comp sufficient funds from the Jim Buck Memorial Benevolent Fund to be reinstated for the purpose of returning to work or taking an Honorable Withdrawal by September 30, 2008.
- 3) To send the Business Representative to the State Federation of Labor Biennial Convention: reasonable expenses to be reimbursed
- 4) To send Local 80's Business Representative with the other Hollywood Business Representatives investigating developments in New Mexico in July: reasonable expenses to be reimbursed.
- 5) To purchase IMDB Pro to facilitate the Business Representatives' work.
- 6) That Local 80 pay reasonable expenses for interested Executive Board Members to attend the IATSE General Executive Board meeting in San Diego in July.
- 7) To send the Business Representative to Sacramento July 9, 2008: reasonable expenses to be reimbursed.
- 8) To purchase a motorcycle from Bartel's for the 2008 Annual MPTF Fundraiser Raffle (purchased to be reimbursed with raised funds.)

Executive Board meeting of July 13, 2008

Motions passed (unless otherwise noted)

- 1) To concur with the Business Representative's request that the International grant Local 80 exclusive jurisdiction over the representation of all workers in the motion picture equipment rental, manufacturing and services supporting the entertainment industry. (Unanimous)
- 2) To loan an injured-on-the-job member sufficient funds from the Jim Buck Memorial Benevolent Fund to become current on dues for the purpose of returning to work or taking an Honorable Withdrawal by December 31, 2008.
- 3) To retain Thomas C. Short as a consultant for \$500.00 month.
- 4) To postpone consideration of the Budget Committee report until the mid-August Executive Board meeting.
- 5) To proceed with Phase 2 of the computer system upgrade: up to \$50,000.00.
- 6) To accept \$400.00 as payment in full to reinstate a Dropped member as part of a Local 80 Marine organizing campaign.
- 7) To allocate up to \$43,000.00 for the 2008 Annual Family Picnic.
- 8) That Local 80's Retirement dues be brought into compliance with the IATSE Constitution and By-laws: effective immediately for new retirees, and as of October 1, 2008, for current retirees, Plan #3 dues will be equal to not less than the price of an IATSE active per capita stamp plus the mandatory amount determined by the IATSE, and Plan #2 dues will equal not less than the price of an IATSE retiree per capita stamp plus the current Local 80 Survivors Benefit assessment.
- 9) That members of the Budget committee who do not miss three consecutive meetings without excuse have their dues paid by the Local.
- 10) To approve President Ahuna's appointment of a new Budget Committee.

Executive Board meeting of August 17, 2008

Motions passed (unless otherwise noted)

- 1) To continue the existing Local 80 Gold Card Retiree policies established by EB041199-1.
- 2) To send two foursomes to the California Association of Labor Relations Officers' 22nd Annual Golf Tournament and Barbeque Dinner fundraiser: \$880.00.

- 3) That Local 80 contribute \$500.00 to the L.A. County Federation of Labor’s Member-to-Member Fund.
- 4) That the Local 80 Retiree Prescription Co-Payment Reimbursement Plan shall reimburse based on retirement date: eligibles with an effective date of retirement after December 31, 2002 shall be reimbursed at 80% of the rate reimbursable for eligibles with an effective date of retirement before January 1, 2003.
- 5) To not purchase earthquake insurance.
- 6) To purchase Craft-specific flags and banners for the Crafts represented by Local 80.
- 7) To deny an Applicant’s request that four late fees be waived.
- 8) That a Local 80 Marine member who was placed on the Industry Experience Roster as a Grip in 2004 be charged the 2004 Grip initiation fee in 12 monthly installments.
- 9) To purchase a quarter-page ad in Local 873’s 50th Anniversary Magazine: \$575.00.

Executive Board Meeting of September 14, 2008

Motions passed (unless otherwise noted)

- 1) That the minimum acceptable information to be contained on documentation for the Local 80 Retiree Prescription Co-Payment Reimbursement Plan shall be; patient name; Rx number; pick-up date and dollar amount.
- 2) That receipts or other documentation submitted for the Local 80 Retiree Prescription Co-Payment Reimbursement Plan be destroyed after the minimum required storage time.
- 3) To allocate \$1,000.00 to print and frame photos for the Local’s office space.
- 4) That Local 80 Retiree Prescription Co-Payment Reimbursement Plan receipts shall have the prescription description name blacked out.
- 4a) To postpone Motion 4 until the next regularly scheduled mid-month Executive Board meeting.
- 5) To contribute \$1,000.00 to the LAUSD 2008 – 2009 Academic Decathlon.
- 6) To renew the telephone system maintenance agreement: \$2,253.60.

Executive Board Meeting of October 5, 2008

- Secretary - Treasurer’s Report
- Business Representative’s Report
- Committee Reports
- Communications
- Unfinished Business
- New Business
- Good and Welfare
- Adjournment: not later than 12:30 PM

NOTE TO KEY GRIPS and CRAFTS SERVICE: The Key Grip/Crafts Service department heads are responsible for determining that there are no members of his/her crew in violation of Article XV Section VI of the Local Eighty Constitution and may be charged with such responsibility before the Local Eighty Executive Board should violations be found under Article 1 Section 1 of Local Eighty’s By-Laws.

NBC Universal GRIP

- Automated inventory system
- Loading and holding bays
- Expanded inventory
- Steel Deck, Scaffolding
- Large supply of motors and box truss
- Scene Dock
- Rigging crews available on-lot and off-lot
- Ability to accommodate additional needs for key grip rental packages
- Canvas Room
- Pre-loaded 5 and 10 ton grip trucks

818.777.2291 • 800.892.1979 THE FILMMAKERS DESTINATION WWW.NBCUNI.COM/STUDIO

NBC UNIVERSAL
MEDIA WORKS
MEDIA TECHNOLOGY & OPERATIONS

NBC BURBANK **UNIVERSAL STUDIOS** **NBC NEW YORK**

Classified Advertising

FOR SALE, LEASE, OR RENT: 4 hood, and 4 side mounts. Best in the movie business. Carl Manoogian, 818-784-1834

FOR RENT: Crafts Services Truck, Loaded Looks great, plus U make money 500 wk last rent for 1200 wk, Call Peter Popp 323-350-3269

FOR RENT: Craft Service Truck, Triple sink, all stainless, soda cooler, double traulson, can help with package if needed. Available for long term call 818-437-6956. 661-510-6287

FOR SALE OR RENT: Crafts Services truck, 2000 Frieghtliner fully equipped with stainless steel double door refrigerator, freezer, sandwich bar, sink, diamond plated floors, 4 jockey boxes, 13 KW lowboy generator, Rubbermaid cart, food cart, and coffee cart. Food prep. table, plenty of cabinet and storage space. Must see. Call Darin at 805-217-5716.

SCUBA EQUIPMENT FOR SALE: Diver propulsion vehicles, Dacor Seasprint \$700, DPV Farllon MK7E underwater scooter 2.7mph 400fsw gauge mount and new fast charger, two Amphibico underwater camera housing with 3 Sony VX1000 DVCAM, 2 HMI lights 20 batteries, 6 charges, 2 color monitors, 4 color filters, 6 diopters, 4 cases, plus extra parts and much more \$5000. Scubapro Thermal Tec Steamer wetsuits, 5mm, Large \$75, and 2mm, Large \$35, Scubapro 2 sets S600 & mk25 \$150. for each 1st and 2nd stage regs, Contact Charles Simons 310-621-3837

FOR SALE: Giraffe Classic Camera Crane (remote 31' & rideable 24'). Complete with 84' aluminum track, new weight carts, brand new 20' custom trailer, tools, and more. \$50,000 OBO. Please call Joe for more details at 818-439-1034

FOR SALE: Spider Hi Hat, 4 way level head, 50% off. 213-507-0479

FOR SALE: 2-12'X30' Digi Green

Screens, New, perfect condition. Made by Forepeak. Sewn edge with grommets. \$705.00 for both. Contact Darren 213-910-0169 in Burbank.

FOR RENT: 45' production trailer. Full length jockey boxes, side door w/ steps, air ride, new rubber and Alcoa rims, 7' aluminum articulated lift gate. Adjustable shelves with office and locking cabinets. Load your gear for feature or T.V. I also have a very clean Kenworth cabover tractor to pull the trailer. Can make a package deal if you need both the tractor and trailer. Call Jerry Enright, 818-903-0750.

FOR SALE: 10 ton 1991 Freightliner with 350 Cummins engine, only 430,000 miles and in excellent running condition, 28ft. box w/shelving and a 6ft. Interlift gate. Call 213-447-2067 for info and pricing.

FOR SALE: Crafts Service Truck, \$22,000, Call Jeff Winn 818-841-0043

FOR RENT: Crafts Services trailer, fully equipped and clean! Comes with cappuccino machine, coffee maker, fridge, freezer, a/c unit, popcorn and hot dog machines, tv/dvd, oven, baskets/containers, tables, and a generator. Available for long and short term. Call Mike at 310-963-1369.

WANTED: Used Grip Equipment c-stands, hi-rollers, mombos, combos, carts, sandbags, reflectors, rags, etc. 818-517-9492

FOR SALE: 14' Craft Service Truck. 2000 Ford w/low miles in excellent condition. Newly installed Stainless Steel Counter Tops, Cabinets, Walls, Sinks w/ hot & cold running water, Diamond Plate floor, Air Condition, Refrigerated Sandwich Bar, Upright Refrigerator/Freezer, Lift Gate w/ stairs & hand rail. \$16,000. Call Dave 818-939-9287

FOR SALE: Motor Boat, 2001 Wellcraft, 2600 Martinique, 27' 5" length, aft cabin, electric stove,

microwave, VHF, Df, GPS, radar, vacum flush head, CD player, sleeps 6 \$39,000 or best offer. Call Barry 805-432-7696.

FOR SALE: 27 pullys, rated to 650#, 25 3/8" shackles. Cost \$445, sell for \$200. Call Mike, 818-294-8838.

FOR RENT: Our friend Tom is gone, but part of his legacy lives on! SuperSliders are back, 28", 3', 4', 5', and 6'. Call Scott @ 310-560-8622, www.supersliders.net

FOR SALE OR RENT: 16 ft. air cond. Crafts Service truck: fully loaded with 2 frigs (one included in sandwich bar), lots of cabinets and counter space, coffee maker, and television. Very clean! Runs great, has new tires. \$10,500.00 obo. Rental Rate, \$450.00/week \$90.00/day. Call Laban Freeman @ 818-399-9563 (cell) or 818-845-5949.

FOR SALE OR RENT: Craft Service Truck, Dbl Door Refrig, Lrg. Beverage Refrig, Condiment Refrig, Microwave, Bunn 3-brnr Coffee Mkr, Lrg. Freezer, New Counters & Cabinets, Hot & Cold Water Dispenser, Air Conditioner. Contact Don, 562-433-3383.

Classified Ads can be placed by sending ad information to:

Local 80

attn: Kent, the*eightynews*
2520 W. Olive Ave., Suite 200
Burbank, CA 91505
Fax to 818-526-0711
email: mail@iatselocal80.org

or bring ads to the Membership Meeting. All ads must be accompanied by a telephone number of the person who is placing the ad and \$5.00. the*eightynews* reserves the right to edit ads.

Any problem with an ad, please call Kent Jorgensen at 818-526-0700, so future problems can be avoided. Local 80 is not responsible for advertisers' claims.

LOS ANGELES
NEW YORK
CHICAGO
DALLAS
NEW ORLEANS
MIAMI
NASHVILLE

and our newest location
SHREVEPORT
with TEAM SHARK

TECHNOCRANE
STRADA
LIBRA HEAD
SCORPIO HEAD
HOT HEAD
POWER POD
CAMERA SLIDERS

Ask about our newest equipment

20' SUPERTECHNO

PRECISION TRACK for 20' & 30' SUPERTECHNOS

MOTORIZED TECHNO BASE

PANAMOUNT

818.316.1080
www.panavision.com

Real Estate Corner

Buyers jumped into the resale housing market during July & August, pushing sales of existing single-family homes in the San Fernando Valley up 16.2 percent from a year ago and 6.9 percent higher than the June. The numbers indicate that the market is at the bottom with sales on the upswing. Demand is increasing because people realize that what they could not afford before they probably can afford now. Come next year, people who are waiting will find that they will be paying more. There were 6,950 active listings throughout the San Fernando Valley at the end of July, down 3.4 percent from a year ago. Of that total, single-family homes accounted for 75 percent of the active listings. At the current pace of sales, the active inventory represents a 7.5-month supply - slightly higher than the 5- to 6-month supply deemed to represent a balanced market. Lenders are finally getting it, but they are taking their time and letting offers accumulate. Purchases of foreclosed properties go fairly smoothly, but short sales are taking a lot more work and more time for a sale to close as lenders make borrowers jump through more hoops.

For Union Members, I will Pay The Escrow Fee When I represent You For The Purchase or Sell Of Your Home. Offer Is Valid At A Successful Close Of Escrow & Some Restrictions May Apply.

Attn: Home Owners!

Not All Agents Are Created Equal! Before You List Your Home Make Sure You Know Your Agents Credentials.
Call Me For a FREE Market Analysis Of Your Home. I also specialize in Short Sale & Foreclosures.

	<p>Victor A. Broker Associate Cell: (818) 618-5475 Email: brokerrealestate@sbcglobal.net</p>	
--	---	------

This is not intended as a solicitation if you are currently working with another agent.

The "Grip friendly" camera movement system

"original"

The Slider...™ LLC

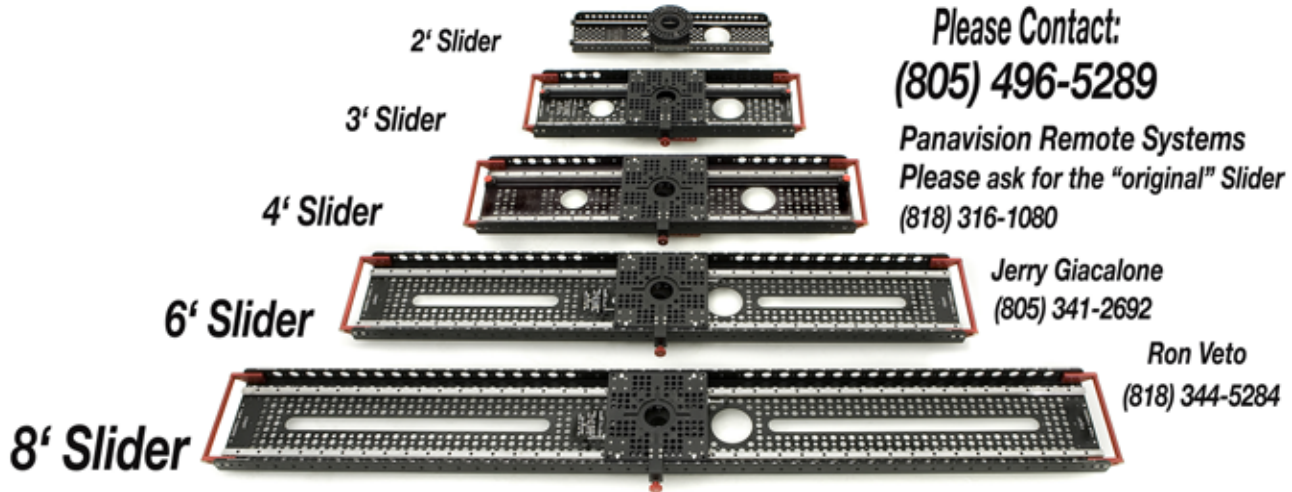

Please Contact:
(805) 496-5289

Panavision Remote Systems
Please ask for the "original" Slider
(818) 316-1080

Jerry Giacalone
(805) 341-2692

Ron Veto
(818) 344-5284

Slide to: **TheSlider.com.**

@Jud Mackelvy
Studio1412.com

***THE NAGGING WON'T STOP UNTIL YOU
TAKE THE RIGGING SAFETY CLASS!!!!
THE DEADLINE IS NOVEMBER 30***

The Safety Pass: 818-502-9932 or www.csatf.org

Local 80 Officers	Secretary-Treasurer	Mike Santoro	Trustees
President	Rick Schunke	Bill Sordal	Tommy Adams
David Ahuna	Executive Board	Gil Valle	Melinda Gordon
Vice President	Jim Chizmar	Eric Whitehead	Fred Perdue
Bob Babin	Pat Daily	Page Williams	Assistant B.A.s
Business Agent	Kent H. Jorgensen	Sergeant-at- Arms	David Ahuna
Thom Davis	Lloyd Moriarity	Chris Adams	Craig Conover
	Russell Nordstedt		Russ Nordstedt

the eighty news is published by: IATSE Local 80 2520 W. Olive Ave. Suite 200 Burbank, CA 91505	800-994-1080 818-526-0700 ext. 701 818-526-0719 fax	email: mail@iatselocal80.org Editor: Kent H. Jorgensen IATSE Local 80 Website: www.iatselocal80.org
--	---	--



c/o Local 80
2520 W. Olive Ave
Burbank, Ca 91505

General Membership Meeting in Oct 5th

Calendar

October

- ◆ 5th, 10:00 am: General Membership Meeting
- ◆ 19th, 9:00 am: Executive Board Meeting

November

- ◆ 2nd, 10:00 am: General Membership Meeting
- ◆ 16th, 9:00 am: Executive Board Meeting

1st Quarter Dues are Due Dec 31