



Crew Stands Up to Producer Local 80 Helps



International President Matt Loeb stands with Local 80's David Ahuna, Russ Nordstedt, and other IATSE representatives (above). Ahuna, Nordstedt, and Craig Conover (above right) have been on the picket lines daily supporting the efforts of the crew of Mega Storm a Larry Levinson Production. Levinson Produces dozens of shows a year which, if the strike is successful, will become union jobs for our members.



Calendar

May 3, 10:00 am General Membership Meeting

June 7, 10:00 am General Membership Meeting

May 17, 9:00 am: Executive Board Meeting

June 28, 9:00 am: Executive Board Meeting

May 25: Memorial Day Holiday; Offices Closed

July 4: Independents Day Holiday; Offices Closed

IN MEMORIAM

Vincent Zarlengo: Born: 06/03/45 Obligated: 09/24/96 Died: 04/18/09

George B. Hollis: Born: 06/06/1924 Obligated: Unknown* Died: 04/21/09

Members' names are announced in this space upon the receipt of official notification of death. Official notification generally means an original death certificate or a report from the Motion Picture Industry Pension and Health Plans.

*Brother Hollis is believed to have retired shortly after working on the 1970 feature, "Monte Walsh." Sadly, although there are still a few retirees who recall him, no official record of his membership remains.







VER SALES, INC.
2509 North Naomi St.
Burbank, CA. 91504
(818) 567-3000 fax: (818) 567-3018
"Over 30 years in the entertainment industry"

   	<p>Aircraft Cable Beam Clamps Block & Falls Bungee Cord Cable Assemblies Camera Tape Carabiners Chain Chain Bags Chain Motors Cheseboros Coated Cable Crosby Clips Daisy Chains</p> <p>Doughty Clamps Electrical Tape Eyebolts Felco Cutters First Aid Supplies Flashlights Gaffers Tape Horizontal Lifelines Knives Manila Rope Mtn. Climbing Rope Multiline II Nicopress Pipe Clamps</p> <p>Pony Clamps Pro Master Rope Sash Cord Safety Cables Shackles Snaps Spansets Stage Set Steel Slings Trick Line Turnbuckles Velcro Web Slings</p>	   
--	--	--

Rigging • Fall Protection • Hardware • Safety • Rescue Equipment

See us on the web at www.versales.com and www.versafety.com







Be Safe When Production Starts Up This Summer

by Kent H Jorgensen

We are coming up on the traditional start of production season. While no one has a crystal ball to see what kind of a year the industry is going to have, the optimistic view is we are going to start sending people to work. Using this rosy view, there are some safety guidelines to remind workers of as they go back to work.

A big safety risk to be aware of is heat illness. A couple of years ago there were a large number of deaths in California due to high, outside temperatures. Cal OSHA responded by creating new regulations for working in heat.

If you are going to be working outside, production should have safeguards in place to protect the crew and cast from heat illness. The safeguards may include tool box talks, training, appropriate clothing, a place to get out of the sun and cool off, and water. Adequate water and recognizing when some one is beginning to have a problem are very important. Many people will be unaware of their own symptoms so it is important for us to watch out for each other. Here are some signs to look for: Headache, fatigue, blurry vision, confusion, lack of sweating or excessive sweating, muscle pain/cramps, and fainting. A good resource for how to deal with heat illness is Industry Wide Safety Committee, Safety Bulletin (Safety Bulletin) #35.

Other weather related conditions to be aware of are summer storms. Lightning, wind, and floods from severe storms can place a production in harms way. Safety Bulletin #38 deals with severe weather, and it recommends that the production has an action plan to deal with the weather.

If you will be working where thunderstorms are possible the production's action plan should have a rule for when crew should seek shelter from lightning. If it does not, suggest that the National Oceanic and Atmospheric Administration's (NOAA) guidelines be used. There are two rules for when to seek shelter. First, "When thunder roars, go indoors." If you hear thunder it is possible to be struck by lightning. Second, use the "30-30" rule. Seek shelter if the time between seeing lightning to hearing thunder is 30 seconds or less. You should stay under shelter for 30 minutes after hearing the last thunder clap.

The weather not only invites production into the wild, but it will wake up the wild. Irritating and potentially dangerous bugs, critters, and plants will be looking for a chance to bite you. Safety Bulletins # 27, Plants and #31, Critters offer guidelines for dealing with the problems.

Water is another inviting element for this time of year. Portraying the fun of getting wet will put crews near, on, or under bodies of water from pools to oceans. For guidelines for working around water refer to Safety Bulletins #7, Diving, #15, Boating, and #17 Water Hazards. If diving and boating operations, other than craft specific tasks, are suppose to be handled by Local 80 Sisters and Brothers. Please inform the Local if someone else is doing this work.

Cross your finger and put on your rose colored glasses. The half full glass may get filled the rest of the way at any time. When you go back to work remember at the end of the day to get back home in one piece.

"When thunder roars, go indoors," NOAA

The Industry Standard
Quick and safe camera movement
Large or small format cameras

32" Mini-Slider, 3', 4', 6' and 8'
motorized Sliders

NEW!!

Slide to: TheSlider.com

TM
Original
The Mini-Slider... LLC
Camera Movement System

Mitchell or Ball adaptable

For Sales or Rental
805-496-5289

<p>M.E.L. Cinema Crane Inc.</p>   <p>Michael E. Listorti Dolly Grip 818-601-0125</p>	<p>American Red Cross</p> <p>1(800) GIVE LIFE 1(800) 448-3543</p> <p>www.redcross.org</p> <p>Questions? Call toll-free: 1 (800) 214-0441 E-mail: bloodquestions@usa.redcross.org</p>
--	---

You Are Cordially Invited To Join Us

J.L. Fisher, SOC, ICG & ASC 4th Annual Mixer & BBQ Lunch



Saturday, May 16, 2009
10:00 AM - 4:00 PM



J.L. Fisher
1000 West Isabel Street
Burbank, CA 91506



Exhibiting Companies

The Camera House, Panavision (Cameras and Remotes), Clairmont Camera, BandPro, Moviola, Mole-Richardson, Doggicam, Mathews Studio Equipment, Sim Video, Panasonic, JVC, Innovision Optics, Filmtools, Camera Dynamics-OConnor, AbelCineTech, Arriflex (Cameras and Lights), Ste-Man Cartoni, Burrell Enterprises, Photosonics, Birns and Sawyer, Hot Gears, Kino Flo, Litepanels, HD Camera Rentals, Imagility, Lightning Strikes, Element Technica, Local 80, Digital Cinema Society and others. (Subject to change without notice)

J.L. Fisher Facility Tours
provided by Jim Fisher at
11:00 AM and 12:30 PM



The Moving Camera Operation Seminar

Please join us in the sound boom room at J.L. Fisher with members of the ASC, SOC, Local 600 (Camera Guild) and Local 80 (Grips). Moderated by George Spiro Dible, ASC. The seminar will focus on the working relationship between the Cinematographer, Camera Operator, 1st AC, Key Grip and Dolly Grip when using Dollies and Jib Arms.
2:00 PM –3:30 PM



Parking will be available at neighboring lots on Isabel Street, signs will be posted. No RSVP required.

Letter to the Editor

In These Times What Tribe are You Part Of?

Tribes. Why do we as people divide ourselves into tribes? The big picture gives us the Arab vs. Jewish hatred in the middle east, Catholics vs. Protestants in Ireland, Here at home Democratic vs. Republicans, Grips vs. Bloods, Ford vs. Chevy, Mac vs. PC, Grips vs. Electricians. Tribes. I don't get it, and I am guilty of it (I like Fords and Macs.)

There is one kind of tribal allegiance that I think we should eradicate. Last month I was working for the LA Opera, teaching two Local 33 stagehands how to run a 3D wire system installed at the Dorothy Chandler. As we were installing it I was working in the busy backstage area, and as I was running out data lines I needed to get past some stagehands, "Excuse me Brothers" I said as I needed to pass, and one guy asked me if I was in Local 33? "No, local 80" I told him. "Then you are no brother if mine" was his reply. I was stunned, and the only thing I could think of saying was "In a country where only 8% of working people are union members, every union man is my brother". Later the next week, the same stagehand was bloating that Local 80 grips don't know

how to rig. I suggested that he worked in a building with ropes hanging from the ceiling, and that anybody could rig in here, but if I had his attitude, a Local 80 man wouldn't be there teaching Local 33 how to use this equipment.

A few weeks ago I got into a lively discussion with an E-Board member about teaching safety training to union members in New Mexico. "F@&# them, there stealing our jobs!" he said. These are union members in America, not foreign film workers! Tribes again.

This has got to stop. Union membership in the US has been in decline for decades, and is directly tied to the rise and fall of the middle class. The more we divide and fight between ourselves, the easier we make it for our real enemy, Big Business. That is whom we need to align ourselves against. They are certainly aligned against us.

Every Union Man and Woman is my brother and sister! And a member of my Tribe.

In Solidarity,
J. Patrick Daily



\$50.00 for Riders

\$20.00 for Passengers

For More Information Call the Local 818-526-0700

George Noma Owner/Designer/Builder



Studio Trucks, Trailers and Carts
Repairs, Maintenance and Customization

(888) 315-NOMA **NomaFab.com**
 20812 Lassen Street Cell (805) 889-6867
 Chatsworth, CA 91311 Fax (818) 341-8350

STRAIGHT SHOOT'R
 cranes



The Straight Shoot'r is a unique jib-arm combined with a linear Z-axis sliding camera mount.

It offers you effortless floating steadycam-like moves, straight-line dolly moves, and everything in between.

For rental information: (818) 609-8310
 or: www.StraightShootr.com

NBC Universal **GRIP**



- Automated inventory system
- Loading and holding bays
- Expanded inventory
- Steel Deck, Scaffolding
- Large supply of motors and box truss
- Scene Dock
- Rigging crews available on-lot and off-lot
- Ability to accommodate additional needs for key grip rental packages
- Canvas Room
- Pre-loaded 5 and 10 ton grip trucks

818.777.2291 • 800.892.1979 THE FILMMAKERS DESTINATION WWW.NBCUNI.COM/STUDIO

NBC UNIVERSAL NBC BURBANK UNIVERSAL STUDIOS NBC NEW YORK

MEDIA WORKS
 MEDIA TECHNOLOGY & OPERATIONS



CraneShot
 by Jan

Technocrane Services

with

* SCORPIO Remote Head
2- Axis or 3- Axis

* SCORPIO Stabilized Head

Call 310-577-1185 or e-mail: pia@craneshot.us

for additional information and quotes

From the Desk of the Secretary-Treasurer

There have been a lot of calls regarding “the Actors’ strike” being over. The callers want to know when everyone is going back to work. There are a couple of things wrong with these calls: first, the Actors haven’t been on strike, and, second, anybody who can read the future well enough to know when work will start up would have to be insane to waste their time working for a living.

Okay, I’ll grant you that the first point is pretty much nit-picking, since the practical effect of the Actors’ intransigence has been much the same as if they had gone on strike.

On the second point, though, I’ll stand firm. Anybody who is able to confidently and accurately predict when the industry is going to get busy again here in Hollywood should be able to easily make a fortune at the track or playing the stock market. They certainly wouldn’t have to make ends meet running the callboard for Local 80.

What’s my point? Only this: neither any of the Call Stewards nor any of the Business Representatives (and most certainly not the Secretary-Treasurer) are able to predict when work will pick up again. Calling the Local to ask that question is a waste of their time and yours.

The Employee Free Choice Act is being reviled by Business as a disastrous, world-as-we-know-it-ending piece of legislation that would strip away the right of workers to have free and secret elections to choose (or, as they would have you believe, reject) a union.

They are outspending Labor by ten (or more) to one on the issue while decrying the fact that unions are using members’ dues money to lobby in favor of the bill. The fact that they are spending stockholders’ (many of whom are themselves union members) money to run their campaign is carefully ignored.

Even worse is the fact that Business, in the absence of any legitimately persuasive argument, has fallen back on the technique of the Big Lie.

The lie, in this case, is essentially their entire argument: “The EFCA would abolish secret ballot elections for workers forced to make a choice about union certification.”

The EFCA, if enacted, would not replace

the National Labor Relations Act, and the NLRA specifically protects the right of workers to a secret ballot election when an employer refuses to recognize a union as the workers’ bargaining agent based on the workers’ signed certification cards.

What the EFCA would actually do is to force a company to recognize a union as its employees’ bargaining agent based on signed certification cards, removing the company’s currently lawful option of demanding that an election be held despite the fact that a large majority, or even all, of its employees have already requested that a union represent them.

To cite a real-life example: eighty-five percent of the employees on “Mega-storm,” a Larry Levinson Productions project, signed certification cards, yet the company refuses to recognize the IATSE as the bargaining agent for its employees. Employees who were so fed up with the treatment they were receiving that they walked off the job even in these difficult economic times, along with union members (mostly Local 80 members, I’m proud to say) are picketing as this is being written.

It is illuminating, when considering the hand-wringing pleas of Business to not let the EFCA pass because it would strip away the secret ballot for union certification, to reflect on the fact that they never seem in the least worried that the NLRA does not demand a secret ballot election for the de-certification of a union.

The Employee Free Choice Act will come up for a vote before long. If you don’t already know, find out who your representatives are in the Senate and the House, and call and write them to strongly urge their support of the EFCA.

(Meanwhile, Larry Levinson Productions is so determined to deprive their employees of their legal right to collective bargaining that the company is bringing in scab labor from other States to fill the abandoned positions. If you would like to show our fellow workers that you support their struggle, call the Local and find out where you can help. Visiting a picket line even for a short time can do wonders for the morale of the workers who are sacrificing so much to try to force their employer to respect their rights.)

MEMBERS SUSPENDED FROM MEMBERSHIP

As of April 22, 2009

Article XV Section VI

“Any member three months in arrears for dues shall be suspended.” Per Article XV Section VI of the Local Eighty Constitutions & By-Laws, the following members have been suspended from membership:

Abdullah, Joseph J	Cooley, Demetrie	Gregori, Anthony	McKee, Matthew Michael
Ambriz, Luis	Corliss, Terence L	Griffith, Robert	Mendez, Melissa S
Ambrocio, Guillermo Antonio	Cornelius, Kathryn	Gursey, Jeremy	Mendez, Michael A
Ammon, Jeremy R	Coscia, Daniel	Gutierrez, Elias Alberto	Merrill, David L
Andersen, Danny M	Costa, Damian F	Hagadorn, Bernie D	Michels, Raymond E
Antin, Bryan F	Crivier, Charles Nicholas	Haizlip, Daniel R.J	Milam, Jake L
Arp, Harold E	Crompton, Richard	Hale, Jeffrey Lawrence	Miliotti, Patricia A
Atherton, Tony	Cruz, Alexander	Hamacher, Paul B	Miliotti, Steve M
Aubry, Philippe	Cruz, Balentin A	Harris, David	Miliotti III, Stephen M
Bailey, Robert Dean	Curtis, Jeffrey Wade	Hatchitt, John M	Miller, John F
Banks, Matthew Leroy	Davis, Kenny E	Head, Robert	Miner, Corey
Barcena, Steve Edward	Davis, Rick	Hedgecock, Donna	Moad, Michael J
Barcroft Jr., Billy Leroy	Davis, Shannon Phillip	Heffernan, Patrick	Molloy, Francis
Barfield, Daniel James	DeGeorge, Mark	Herrera, Rene	Monroe, Christopher L
Barrows, Dan	Del Castillo, Bruce	Heywood, James Stephen	Moriarity, Christopher
Baukind, Martin H	Denman, Eric	Hicks, Jake T	Morris III, John P
Beaird, Cory Christian	DeSilva, Allen	Hogan, Thad William	Mott, Josh
Beaird, Kelly Christopher	Dickey, Arturo Joe	Holechek, Brian Joe	Narvaez, Ramiro
Beaird, Nicholas Benjamin	Doane, Patrick	Holiday, Brandy	Narvell, Scott David
Beran, John	Dole, Douglas L	Hunadi, Shawn Thomas	Nemeth, Jeff
Blackman, William J	Donaldson, Reginald	James, Amos A	Neu, Joseph
Borden, Clint J	Drevlo, Kyle Ross	James, Nathaniel W	Nevarez, Gilbert Anthony
Boyd, Kela L	Drnec, Tim	Jett, Michael Montez	Noble, Tim
Brewer-Fee, Lisa	Duarte, Michael Robert	Johnson, Darren	Novitsky, Fabio
Brown, Charles D	Dunford, James C	Johnson, Robert Thomas	Padilla Jr, Donald M
Browne, Darwin	Edwards Jr., Larry Duane	Kaplan, Michael Phillip	Papajohn, Christopher Gus
Browne, Thomas V	Erler, Adam Wayne	Karidis, Perry	Patchen, Robert John
Bullen, David	Escobar, Samuel	Kemp, David M	Pavlovits, Petra
Burkes, Otis D	Everly, Vincent G	Kennedy, Ted Scott	Paul, William E
Caldwell, Anthony Quinn	Fabian, Matthew	King, Dean Michael	Pearce, Chad M
Cameron, Frank	Febbo, Scott A	Klein, Raymond	Pearson, Jim W
Campbell III, David D	Felix, Colin	Koth, John R	Powers, Derrell
Campbell Jr, Michael J	Ferguson, Ian	Kuhn, Joshua M	Prior, George Carr
Carceller, Ken	Fezzey, Richard R	Kurges, Steve Michael	Prophet, Roy Steven
Carden, Kyle Richard	Final, Shannon Leigh	Lambie, Louie Sanschargin	Quijano, Edwin
Cardenas, Adam	Fiorelli, William A	Landsberg, Gregory K	Ramage, Mark
Carmer, Steven Wayne	Fisher, Eric Ronald	LaRosa, Leonard	Randolph, John
Carter, Willie	Flaningam, Michael	Leite, David Harold	Rendon, Sergio
Catanzarite, Michael	Fleischbein, Neil Damon	Lood, Brett Daniel	Reyes, Michael Anthony
Cavaliere, R. Christopher	Flores, Jason Rene	Lovejoy, Michael	Reyes, Michael Joseph
Centrella, Chris	Flynn, Kevin	Lucchese, Christopher C	Rice, Steven John
Cerrone, Donald J	French, David John	Lyle, Alison	Rideau, Michael Dean
Chapman, Mark	French, Michael Robert	Maahs III, William L	Riker, Gustav
Chase, Matthew James	Fusca, Damian Gioso	MacNeil, Aengus	Ritts, Liesl
Chavez, Joe	Galleguillos, Andres	Malone, Daniel F	Roberts, Dale L
Chickanis, Kevin	Gambino, Mark J	Manos, John	Robison, Andrew Kent
Chizmar Jr., James M	Garcia, Daniel	Martin, John T	Robison, Scott E
Cicoello, Albert	Garcia, Erasto T	Mattson, Stephen	Rodnunsky, James
Cicoello, John	Geary, Adam King	Mazzola, Dominic Anthony	Rodriguez, Robert A
Clayton, David A	Giacometti, Benjamin M W	R	Roffman, Avraham
Coakley, James J	Gilbert, Bryan	Mc Ateer, Ryan Jennings	Rosso, Brian
Codd, Joseph T	Giordano, Anthony Paul	Mc Inerny, John	Russello, Christopher A
Cone, Wayne T	Good, Gregory	McAleenan, Bill	Ryan, Frank J
Cook, Troy	Gordon, Richard Sanford	McBride, Gary	Ryan Jr., James Michael
	Graves, Kevin M	McCulloch, Byron Scott	Sabella, Fadi

NOTE TO KEY GRIPS/CRAFTS SERVICE: The Key Grip/Crafts Service is responsible for determining that there are no members of his/her crew in violation of Article XV Section VI of the Local Eighty Constitution and may be charged with such responsibility before the Local Eighty Executive Board should violations be found under Article 1 Section 1 of Local Eighty's By-Laws.

Calendar of General Membership Meeting of Sunday, May 3, 2009

Call to Order: 10:00 a.m.

Flag Salute

Roll call of Officers

Reading of the Minutes of previous meetings:

General Membership meeting of April 5, 2009

Executive Board meeting of April 19, 2008

Motions passed (unless otherwise noted)

- 1) To pay a Reinstatement fee for a Suspended injured member due to unusual circumstances.
- 2) To postpone Local 80's participation in the Annual Multi-Local Family Picnic for 2009.
- 3) To allocate \$5,300.00 for the 2009 Retirees' Bus Trip.
- 4) To pay two quarter's dues for Nick Lancaster in appreciation of his extraordinary assistance in organizing.
- 5) To set up a separate account to transfer donated funds to assist striking "Mega-Storm" crew with utility payments.
- 6) To send two fivesomes to the MPTF's 2009 Heartbeat of Hollywood Golf Classic: \$3,950.00.
- 7) To purchase a full-page ad in the 66th Quadrennial IATSE Convention Souvenir Journal: \$1,250.00.
- 8) To purchase a table for the Jewish Labor Committee 2009 Annual Awards Brunch, and a full-page ad in the souvenir journal: \$1,850.00.

Executive Board Meeting of May 3, 2009

Secretary - Treasurer's Report

Business Representative's Report

Committee Reports

Communications

Unfinished Business

New Business

Good and Welfare

Adjournment: not later than 12:30 PM

MEMBERS SUSPENDED FROM MEMBERSHIP (continued)

As of April 22, 2009

Article XV Section VI

"Any member three months in arrears for dues shall be suspended." Per Article XV Section VI of the Local Eighty Constitutions & By-Laws, the following members have been suspended from membership:

Saffery, Shane Edward	Smothers, Waverly	Studenny, Robert J	Wade, Glenn N
Sanchez, Jeffrey J	Smuda, Michael Peter	Taylor, Harold B	Waldron, Andrew D
Sanfilippo, Jim	Sobczak, Andre	Thomas, Fleather D	Waldron, Charles W
Sasgen, David	Soto, Gene	Tilbury, Daniel Andrew	Walters III, Danny
Savage, Steven Richard	Speed, Ron	Tredway Jr., Nicholas Alan	Watkins, Scott David
Schatke, Riko R	Spicka, Timothy	Trejo, Gary	Wells, Scott Edward
Schwartz, Cary	Spitalnick, Mick	Tricarico, William Jerome	Whittlesey, Harold L
Serna, Steven Essex	Stephens, Richard M	Troiano, Joe	Wiest, Jason Daniel
Sherif, Omari	Stevens, Kurtis J	Twiford, Gregory	Wisher, Dana Pierce
Small, Robert D	Stevens, Shawn P	Underhill, Alpheus	Wong, Dennis
Smith, Jacob W	Stewart, Alan W	Van Ermen, Joshua C.	Woods, Charles T
Smith, Scott M	Strauser, Troy	Veto, Ronald G	Wynne, Vernon
Smithey, Alf E	Stroud, Wayne	Via, Darrell Edward	Young, Matthew C

NOTE TO KEY GRIPS/CRAFTS SERVICE: The Key Grip/Crafts Service is responsible for determining that there are no members of his/her crew in violation of Article XV Section VI of the Local Eighty Constitution and may be charged with such responsibility before the Local Eighty Executive Board should violations be found under Article 1 Section 1 of Local Eighty's By-Laws.

CHAPMAN/LEONARD

STUDIO EQUIPMENT, INC. 

CRANES ARMS BASES REMOTE SYSTEMS DOLLIES PEDESTALS

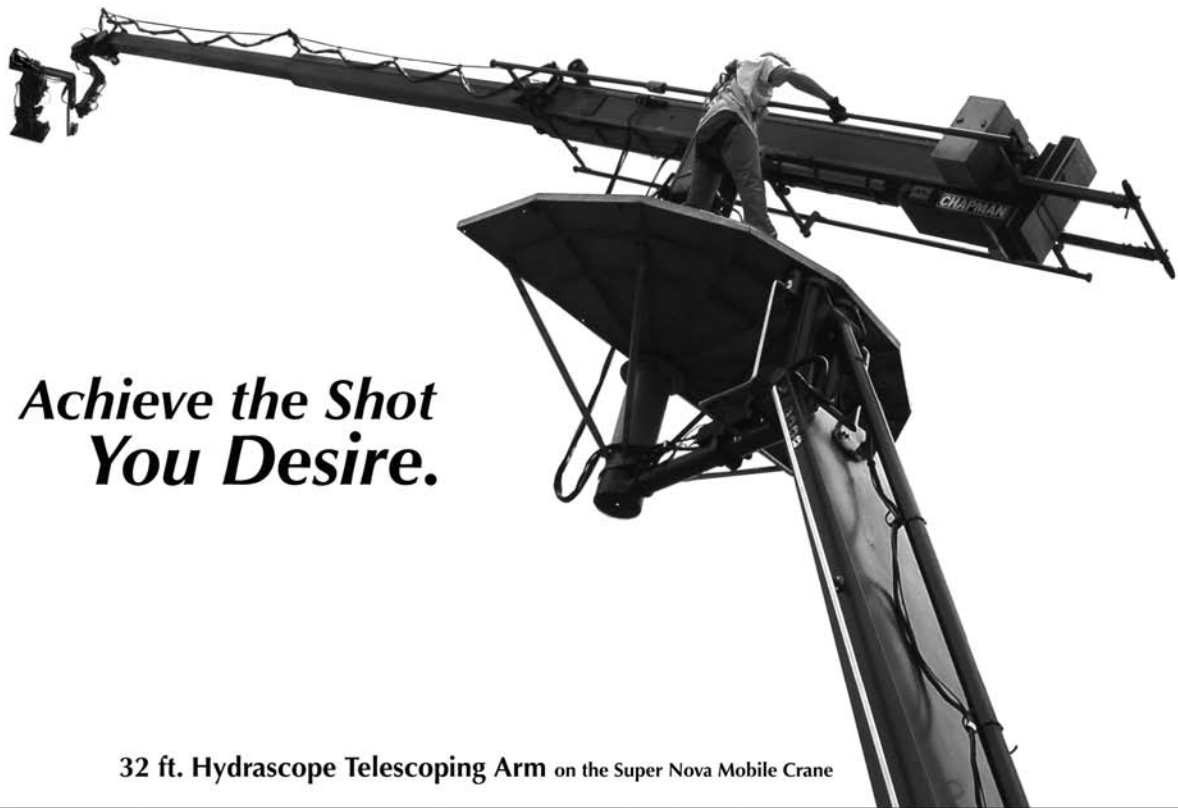

*Achieve the Shot
You Desire.*

32 ft. Hydrascope Telescoping Arm on the Super Nova Mobile Crane



SUPER NOVA on *Martian Child*



HUSTLER IV



LENNY ARM II PLUS on *Eight Below*

LA (888) 883-6559 TX (888) 758.4826 FL (888) 337-8243 Canada (866) 848-2602 UK (888) 883-6559

© Chapman/Leonard Studio Equipment, Inc.

Try our Sound Stage in Orlando, Florida

www.chapman-leonard.com

Classified Advertising

FOR SALE, LEASE, OR RENT: 2 hood, and 2 side mounts. Best in the movie business. Carl Manoogian, 818-784-1834

FOR RENT: Crafts Services Truck, Loaded Looks great, plus U make money 500 wk last rent for 1200 wk, Call Peter Popp 323-350-3269

FOR RENT: 45' production trailer. Full length jockey boxes, side door w/ steps, air ride, new rubber and Alcoa rims, 7' aluminum articulated lift gate. Adj shelves with office and locking cabs. Load your gear for film or TV. Also have a very clean Kenworth cabover tractor to pull the trailer. Can make a package deal if you need both the tractor and trailer. Call Jerry Enright, 818-903-0750.

FOR RENT: Crafts Services trailer, fully equipped and clean! Comes with cappuccino machine, coffee maker, fridge, freezer, a/c unit, popcorn and hot dog machines, tv/dvd, oven, baskets/containers, tables, and a generator. Available for long and short term. Call Mike at 310-963-1369.

FOR RENT: Our friend Tom is gone, but part of his legacy lives on! SuperSliders are back, 28", 3', 4', 5', and 6'. Call Scott @ 310-560-8622, www.supersliders.net

FOR SALE OR RENT: 16 ft. air cond. Crafts Service truck: fully loaded with 2 frigs (one included in sandwich bar), lots of cabinets and counter space, coffee maker, and television. Very clean! Runs great, has new tires. \$10,500.00 obo. Rental Rate, \$450.00/week \$90.00/day. Call Laban Freeman @ 818-399-9563 (cell) or 818-845-5949.

FOR SALE OR RENT: Craft Service Truck, dbl door frig, lrg. beverage frig, condiment frig, micro, bunn 3-brnr coffee mkr, lrg. freezer, new counters & cabinets, hot & cold water dispenser, Air Conditioner. Contact Don, 562-433-3383.

FOR RENT: 5 ton Crafts Service truck, TV or film, ready with 2 frigs, freezer, sandwich bar, 4 sinks,

cappuccino machine, microwave, carts, geni, air cond., tables, hot dog machine, int/ext TVs w/ satellite, etc. Can email pics. Ed 818-209-5389

FOR SALE: 1982, 32' Nomad trailer w/ pop outs, clean in and out. \$6800.00. Trailer in park. \$465.00 a month rent. Sunland area. Must be 55 years old. Call Greg 818-951-4057

LEGAL SERVICES: Been denied Social Security Disability or service-connected Veterans Benefits? West Coast Disability Law Group, LLP is an experienced law firm specializing in So Sec Disability and Veterans Benefits claims. West Coast Disability Law Group has offices throughout So Cal to serve you. To schedule a free consultation, please call 800-459-3017, or e-mail info@westcoastdisability.com. Never a fee for a consultation and no attorneys' fees unless they win your claim.

FOR SALE: EZ Grip 10 ton grip truck 30,000 miles on rebuilt engine. 28' box with lift gate, stainless steel jockey boxes. Excellent grip package. Call Jerry Deats (JD) for more info. 818-366-2043

FOR SALE: 45'x 96" Trailmobile grip production trailer. Extensive extra grip equip package from camera support (car mounts, bazooka, 4' slider, rocker plate, spider hi hat, ladder pod, etc) to fabrication. large speedrail package, carts, geni, pneumatic, cordless and electric power tools. over \$15k in expendables. potential extra \$100k yearly income. Bidding starts at \$65,000 Call Lloyd 805-386-3048.

FOR SALE: Work box, \$850; 4 way leveling riser, \$350; ball joint mount on plate, \$350; Rolling cart for Rigging Key Grips, \$900. Carl Manoogian, 818-784-1834

FOR SALE: White, 2000 Argosy 10 ton built in 2006. 535,000 miles, 29'4" box inside, frame stretch and 18000 lbs front end and new brakes, stainless jockey boxes with lights and custom shelving, Can be grip or electric. Call for info 818-674-6626

Vince.

FOR SALE: Norms hood mount, 50' speedrail dolly track (2-20' and 1-10'), and 200'-1 1/2" speedrail (Great for rigging). Call Jeff Smith for info. 805-558-8012

ROOM FOR RENT: Van Nuys Master bedroom, private bath and entrance, no drugs, no alcohol, no pets, big backyard. Billy Record, 818-785-9090

FOR SALE: Modern-Spider and 4-way level head. 213-507-0479

FOR SALE: 3 mini hood mounts, 2 fender brackets, 2 hook brackets, 1 camera plate: \$350.00 each. Carl Manoogian, 818-784-1834

LOOKING TO BUY: Aero jib arm complete with hard shell cases, counter balance weights and arm cables. Please call Jamie, 310-403-4798 or Danny, 818-326-2457

FOR RENT: 2005 24 ft. Crafts Service freight liner truck fully equipped. sandwich bar, full freezer, frig, sinks, TV, generator. very clean. Available for long or short term. Call Allan, 909-210-7563 or Derek, 661-373-9432

Classified Ads can be placed by sending ad information to:

Local 80

attn: Kent, *theeightynews*

2520 W. Olive Ave., Suite 200
Burbank, CA 91505

Fax to 818-526-0711

email: mail@iatselocal80.org

or bring ads to the Membership Meeting. All ads must be accompanied by a telephone number of the person who is placing the ad and \$5.00. *theeightynews* reserves the right to edit ads.

Any problem with an ad, please call Kent Jorgensen at 818-526-0700, so future problems can be avoided. Local 80 is not responsible for advertisers' claims.

LOS ANGELES
NEW YORK
CHICAGO
DALLAS
NEW ORLEANS
MIAMI
NASHVILLE

TECHNOCRANE
STRADA
LIBRA HEAD
SCORPIO HEAD
HOT HEAD
POWER POD
CAMERA SLIDERS

Ask about our newest equipment

20' SUPERTECHNO

PRECISION TRACK for 20' & 30' SUPERTECHNOS

MOTORIZED TECHNO BASE

PANAMOUNT

and our newest location
SHREVEPORT
with TEAM SHARK

818.316.1080
www.panavision.com

Real Estate Corner

San Fernando & Santa Clarita Valley Homes Sales Are In The Rise!

Home and condominium sales in the San Fernando & Santa Clarita Valley improved dramatically compared to a year ago as a growing number of prospective buyers got off the sidelines to jump into a market that is posting the most favorable resale prices since 2003. The median price of single-family homes sold came in at \$339,900, down 35.3 percent or \$185,100 below the median of \$525,000 posted in 2008. It's impossible to pinpoint when this recession will end, but months of improved home sales suggest the end may be in sight. At the current pace of sales, that represents a 6.9-month inventory, just slightly above the 5- to 6-month supply that represents a balanced market. Prices will remain soft until foreclosures and short sales are behind us, but I do not expect to see any further dramatic declines. If anything, given increased sales activity, prices may stabilize, but neither do I expect any dramatic upward movement in prices anytime soon. An \$8,000 tax credit is available to first-time home buyers for the purchase of a principal residence on or after January 1 and before December 1 of 2009. Call me & I will be happy to explain the details. Some restrictions apply.

Attn: Home Owners!

Not All Agents Are Created Equal! Before You List Your Home Make Sure You Know Your Agents Credentials. Call Me For a FREE Market Analysis Of Your Home. I also specialize in Short Sale & Foreclosures.



Victor Alebian
Broker/Owner
Cell: (818) 618-5475
Email:
brokerrealestate@sbcglobal.net



This is not intended as a solicitation if you are currently working with another agent. The accuracy of all information is deemed reliable but not guaranteed.

JOIN HOLLYWOOD'S PROFESSIONALS IN 2009

For the Pre-Production • Production • Post Production Community



Paramount Pictures Studio Lot, Hollywood, CA
Exhibition & Premiere Seminars: June 5 - 6, 2009
The Film Series at Cine Gear Expo: June 4 - 6, 2009
Master Class Seminars: June 7, 2009



Contact us @
310/472-0809 • info@cinegearexpo.com

CALL FOR ENTRIES!
THE FILM SERIES AT CINE GEAR EXPO 2009
Independent, Student Short Film & Feature Film Competition
ANNOUNCING NEW!
The Expansion Into Documentary Film Competition
Deadlines For Submissions Are:
Early 3.15.09 • Regular 4.08.09 • Late 5.01.09

For more information and updates, visit us at: WWW.CINEGEAREXPO.COM

SCHOLARSHIP APPLICATIONS AVAILABLE

THERE ARE FIVE \$1,000 LOCAL 80 SCHOLARSHIPS AVAILABLE.

THESE GRANTS MAY BE USED FOR ANY FORMAL EDUCATION AFTER HIGH SCHOOL.

THE APPLICANT DOES NOT HAVE TO DECLARE A MAJOR TO RECEIVE A GRANT FROM LOCAL 80;

THEY JUST HAVE TO BE ACCEPTED INTO ANY COLLEGE OR UNIVERSITY, IN THE U.S. OR ABROAD.

LOCAL 80 ACCEPTS SCHOLARSHIP APPLICATIONS FROM:

THE CHILDREN OF MEMBERS IN GOOD STANDING,

MEMBERS IN GOOD STANDING

THE SPOUSES OF MEMBERS IN GOOD STANDING.

LOCAL 80'S ACCOUNTING DEPARTMENT WILL MAIL APPLICATION FORMS AND INFORMATION UPON REQUEST.

APPLICATION FORMS AND ANCILLARY DOCUMENTS MUST BE RECEIVED BY LOCAL 80 BY SEPTEMBER 30, 2009.



Motion Picture & Television Equipment

Model 23 Sectional JIB

6 to 21 feet... In 10 minutes

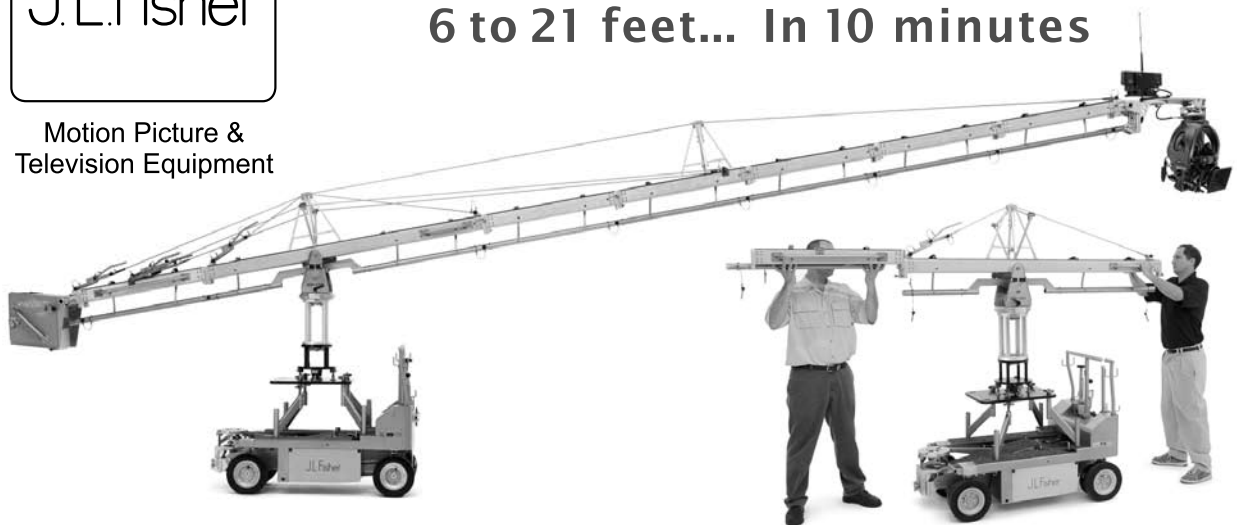

3 foot increments from 6' (1.83m) to 21' (6.4m)

Max payload 131 lbs. (58 kg) @ 21'

"J.L. Fisher products are proudly made in the U.S.A."

J.L. Fisher, Inc. 1000 Isabel Street, Burbank, CA 91506 U.S.A.

Tel: (818) 846-8366 Fax: (818) 846-8699

Web: www.jlfisher.com e-mail: info@jlfisher.com

J.L. Fisher, GmbH Emil-Hoffmann-Str. 55-59 50996 Köln, Germany

Tel: +49 2236 3922 0 Fax: +49 2236 3922 12

Web: www.jlfisher.de e-mail: info@jlfisher.de

The “Original” Rigging Seminar

featuring

Jay Glerum

August 29 & 30

You Must Sign Up for This Class

Call Kent 818-526-0701 or safety@iatselocal80.org

Space is Limited

LOCAL 80 TRAINING COURSES

CHECK OUT THE WEBSITE TO FIND OUT MORE

Hands On Wire Rope Rigging

Sunday, May 31, 8:00 am to 4:00 pm

Hands on practice with truss, chainmotors, slings, shackles, Nico press practice, and more.

See the practical side of the “R” Class

Camera Crane Operation Safety

Sunday, June 7, 1:00 pm to 8:00 pm

This class will teach how to move, assemble and disassemble counter balanced camera cranes.

This is not a class on how to be a crane grip, but for grip who may assist the crane grip moving and building camera cranes.

Local 80 Safety and Training

www.iatselocal80.org

818-526-0701

safety@iatselocal80.org

Local 80 Officers

President

David Ahuna

Vice President

Bob Babin

Business Manager

Thom Davis

Secretary-Treasurer

Rick Schunke

Executive Board

Jim Chizmar

Pat Daily

Kent H. Jorgensen

Lloyd Moriarity

Russell Nordstedt

Mike Santoro

Bill Sordal

Gil Valle

Eric Whitehead

Page Williams

Sergeant-at- Arms

Chris Adams

Trustees

Tommy Adams

Melinda Gordon

Fred Perdue

Business Agents

David Ahuna

Craig Conover

Russ Nordstedt

the eighty news
is published by:
IATSE Local 80
2520 W. Olive Ave. Suite 200
Burbank, CA 91505

800-994-1080
818-526-0700 ext. 701
818-526-0719 fax

email: mail@iatselocal80.org
Editor: Kent H. Jorgensen
IATSE Local 80
Website: www.iatselocal80.org



c/o Local 80
2520 W. Olive Ave
Burbank, Ca 91505

General Membership Meeting May 3

Calendar

May

- ◆ 3rd, 10:00 am: General Membership Meeting
- ◆ 17th, 9:00 am: Executive Board Meeting

June

- ◆ 7th, 10:00 am: General Membership Meeting
- ◆ 28th, 9:00 am: Executive Board Meeting

3rd Quarter Dues are Due June 30